



**UNDER-BODY
CYLINDERS FOR
HEAVY DUTY TIPPERS**
HIGH PRESSURE

DETTAGLI TECNICI • TECHNICAL DATA • DÉTAIL TECHNIQUES • TECHNISCHE DATUM • DETALLES TÉCNICAS

Hydro Service Penta
via Proventa, 31
48018 Faenza RA - Italy
tel. +39 0546 664848
fax +39 0546 664860
hspenta@hspenta.it
www.hspenta.it

Indice • Index • *Index* *Index* • *Indice*



UNDER-BODY CYLINDERS FOR HEAVY DUTY TIPPERS HIGH PRESSURE

2 AP 3 • APS 3

4 AP 2 • APS 2

8 AP 1 • APS 1

12 AP 01 • APS 01

16 AP 02 • APS 02

20 AP 03 • APS 03

22 AP 04 • APS 04

26 Accessori **Accessories** *Accessoires*
Zubehören **Accesorios**

28 Tavole di aiuto **Selection charts** *Table de choix*
Worwählerkarte **Carta de seleccion**

30 Complessivo **Assembly** *Plan du vérin*
Zusammenzeichnung **Dibujo**

31 Avvertenze **Warnings** *Advertissements*
Warnungen **Advertencias**

AP 3 • APS 3

Accessori
Accessories
Accessoires
Zubehören
Accesorios



SUPPORTO CILINDRO CYLINDER SUPPORT
PALIER VERIN LAGER ZYLINDER
SOPORTE CILINDRO



SUPPORTO BILANCIERE CRADLE SUPPORT
BALANCIER VERIN LAGER KIPPHEBEL
SOPORTE CUNA



BILANCIERE CRADLE BALANCIER
KIPPHEBEL CUNA



Vedi pagine 26 e 27 per dettagli
See pages 26-27 for details
Voyez pages 26-27 pour détails
Sehen Blatten 26-27 für Informationen
Ver hoias 26-27 para informaciones

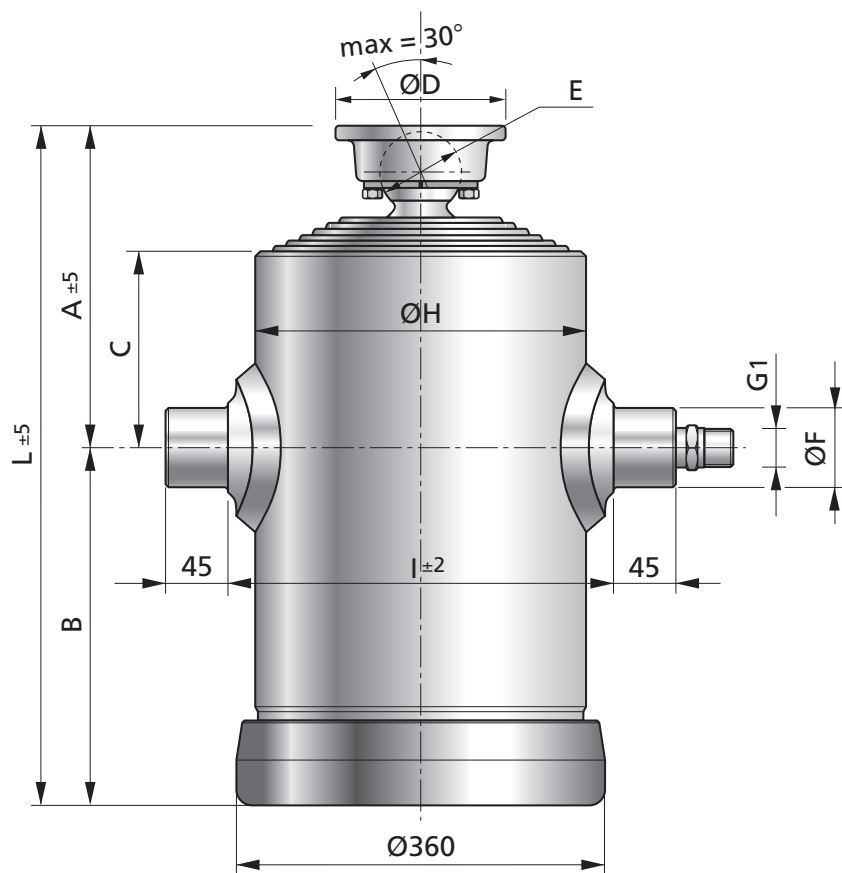

AP 3 • APS 3												
TIPO TYPE TYP TIPO	SFILATE EXTENSION EXPANSION STUFENZAHL EXPANSION	DIAMETRO - DIAMETER DIAMÈTRE - DURCHMESSER - DIAMETRO [mm]										max SPINTA THRUST POUSSEE KRAFT EMPUJE [kN]
		I	II	III	IV	V	VI	VII	VIII	IX	X	
AP 3	10	279	249	221.5	196	174	154	135	116	98	79	314
	9	279	249	221.5	196	174	154	135	116	98		367
	8	279	249	221.5	196	174	154	135	116			421
	7	279	249	221.5	196	174	154	135				480
APS 3	10	279	249	221.5	196	174	154	135	120	105	90	329
	9	279	249	221.5	196	174	154	135	120	105		375
	8	279	249	221.5	196	174	154	135	120			420
	7	279	249	221.5	196	174	154	135				480

AP 3 • APS 3 DETTAGLI TECNICI TECHNICAL DATA DÉTAIL TECHNIQUES TECHNISCHE DATUM DETALLES TÉCNICOS

ART. NUOVO NEW MODEL NOUVELLE DESCR. NEUE BEZEICHNUNG DESCRIPCION NUEVA	ART. VECCHIO OLD MODEL ANCIENNE DES. ALTE BEZ. DES. ANTIGUA	CODICE CODE CODE BESTELL-Nr. CODIGO	N. SFILATE - EXTENSION N. N. DES BALLONNES N. EXPANSIONES STUFENZAHL - N. EXPANSIONES	CORSO - POWER STROKE COURSE DE TRAVAIL GESAMTHUB - CARRERA	MASSA - MASS MASSE - MASSE MASA	OLIO ASSORBITO OIL CONSUMPTION HUILE CONSOMM. ÖLVERBRAUCH ACEITE ABSORBIDO	PRESSIONE MAX DI LAVORO MAX. WORKING PRESSURE PRESSION DE TRAVAIL MAX. MAXIMUM BETRIEBSDRUCK PRESSION MAX. DE TRABAJO	MASSA TOTALE RIPALZABILE TOTAL MASS TIP-UP MASSE TOTALE REBATABLE GESAMTIPPMASSE MASA TOTAL VOLCADA	L	A	B	C	D	E	F	H	I
AP 750 6354 279 10	AP3/750/10	2107502790001	10	6354	413	163.7	200	40.1	923	275	648	140	150	73	70	316	360
AP 750 5717 279 9	AP3/750/9	2107502799001	9	5717	406	160.6	200	46.8	916	268	648	140	150	73	70	316	360
AP 750 5080 279 8	AP3/750/8	2107502798001	8	5080	388	155.8	200	53.7	909	261	648	140	150	73	70	316	360
AP 750 4445 279 7	AP3/750/7	2107502797001	7	4445	370	149.1	200	61.2	930	282	648	140	170	92	70	316	360
AP 670 5554 279 10	AP3/670/10	2106702790001	10	5554	363	143.1	200	40.1	843	275	568	140	150	73	70	316	360
AP 670 4997 279 9	AP3/670/9	2106702799001	9	4997	358	140.3	200	46.8	836	268	568	140	150	73	70	316	360
AP 670 4440 279 8	AP3/670/8	2106702798001	8	4440	351	136.1	200	53.7	829	261	568	140	150	73	70	316	360
AP 670 3885 279 7	AP3/670/7	2106702797001	7	3885	345	130.3	200	61.2	850	282	568	140	170	92	70	316	360
AP S565 4552 279 10	APS3/565/10	2205652790001	10	4552	319	117.9	200	42.0	738	253	485	118	150	73	70	316	360
AP S565 4087 279 9	APS3/565/9	2205652799001	9	4087	316	114.9	200	47.8	731	246	485	118	150	73	70	316	360
AP S565 3624 279 8	APS3/565/8	2205652798001	8	3624	312	110.9	200	54.2	724	239	485	118	150	73	70	316	360
AP S565 3160 279 7	APS3/565/7	2205652797001	7	3160	310	105.7	200	61.2	745	260	485	118	170	92	70	316	360
AP SL 3852 279 10	APSL3/10	22000L2790001	10	3852	287	99.6	200	42.0	668	253	415	118	150	73	70	316	360
AP SL 3457 279 9	APSL3/9	22000L2799001	9	3457	284	97.1	200	47.8	661	246	415	118	150	73	70	316	360
AP SL 3064 279 8	APSL3/8	22000L2798001	8	3064	281	93.7	200	54.2	654	239	415	118	150	73	70	316	360
AP SL 2670 279 7	APSL3/7	22000L2797001	7	2670	280	89.2	200	61.2	675	260	415	118	170	92	70	316	360
AP S470 3602 279 10	APS3/470/10	2204702790001	10	3602	276	93.0	200	42.0	643	253	390	118	150	73	70	316	360
AP S470 3232 279 9	APS3/470/9	2204702799001	9	3232	273	90.7	200	47.8	636	246	390	118	150	73	70	316	360
AP S470 2864 279 8	APS3/470/8	2204702798001	8	2864	270	87.5	200	54.2	629	239	390	118	150	73	70	316	360
AP S470 2495 279 7	APS3/470/7	2204702797001	7	2495	269	83.3	200	61.2	650	260	390	118	170	92	70	316	360
AP SM 2849 279 10	APSM3/10	2200AM2790001	10	2849	245	73.3	200	42.0	567	252	315	118	150	73	70	316	360
AP SM 2554 279 9	APSM3/9	2200AM2799001	9	2554	244	71.5	200	47.8	560	245	315	118	150	73	70	316	360
AP SM 2261 279 8	APSM3/8	2200AM2798001	8	2261	241	68.9	200	54.2	553	238	315	118	150	73	70	316	360
AP SM 1967 279 7	APSM3/7	2200AM2797001	7	1967	240	65.6	200	61.2	574	259	315	118	170	92	70	316	360
AP SB 2499 279 10	APSB3/10	22000B2790001	10	2499	223	65.9	200	42.0	498	223	275	128	150	73	70	316	360
AP SB 2260 279 9	APSB3/9	22000B2799001	9	2260	221	64.4	200	47.8	496	221	275	128	150	73	70	316	360
AP SB 2018 279 8	APSB3/8	22000B2798001	8	2018	220	62.3	200	54.2	494	219	275	128	150	73	70	316	360
AP SB 1770 279 7	APSB3/7	22000B2797001	7	1770	220	59.5	200	61.2	520	245	275	128	170	92	70	316	360
AP SC 2157 279 10	APSC3/10	22000C2790001	10	2157	207	57.2	200	42.0	459	234	225	145	150	73	70	316	360
AP SC 1957 279 9	APSC3/9	22000C2799001	9	1957	206	55.9	200	47.8	459	234	225	145	150	73	70	316	360
AP SC 1752 279 8	APSC3/8	22000C2798001	8	1752	205	54.1	200	54.2	459	234	225	145	150	73	70	316	360
AP SC 1539 279 7	APSC3/7	22000C2797001	7	1539	206	51.7	200	61.2	487	262	225	145	170	92	70	316	360
AP SCC 1871 279 10	APSCC3/10	2200CC2790001	10	1871	193	49.2	200	42.0	426	202	224	118	150	73	70	316	360
AP SCC 1691 279 9	APSCC3/9	2200CC2799001	9	1691	192	48.0	200	47.8	426	202	224	118	150	73	70	316	360
AP SCC 1506 279 8	APSCC3/8	2200CC2798001	8	1506	191	46.4	200	54.2	426	202	224	118	150	73	70	316	360
AP SCC 1313 279 7	APSCC3/7	2200CC2797001	7	1313	192	44.2	200	61.2	454	230	224	118	170	92	70	316	360

AP 2 • APS 2

1/2

Accessori
Accessories
Accessoires
Zubehören
Accesorios



SUPPORTO CILINDRO CYLINDER SUPPORT
PALIER VERIN LAGER ZYLINDER
SOPORTE CILINDRO



SUPPORTO BILANCIERE CRADLE SUPPORT
BALANCIER VERIN LAGER KIPPHEBEL
SOPORTE CUNA



BILANCIERE CRADLE BALANCIER
KIPPHEBEL CUNA



Vedi pagine 26 e 27 per dettagli
See pages 26-27 for details
Voyez pages 26-27 pour détails
Sehen Blatten 26-27 für Informationen
Ver hoias 26-27 para informaciones

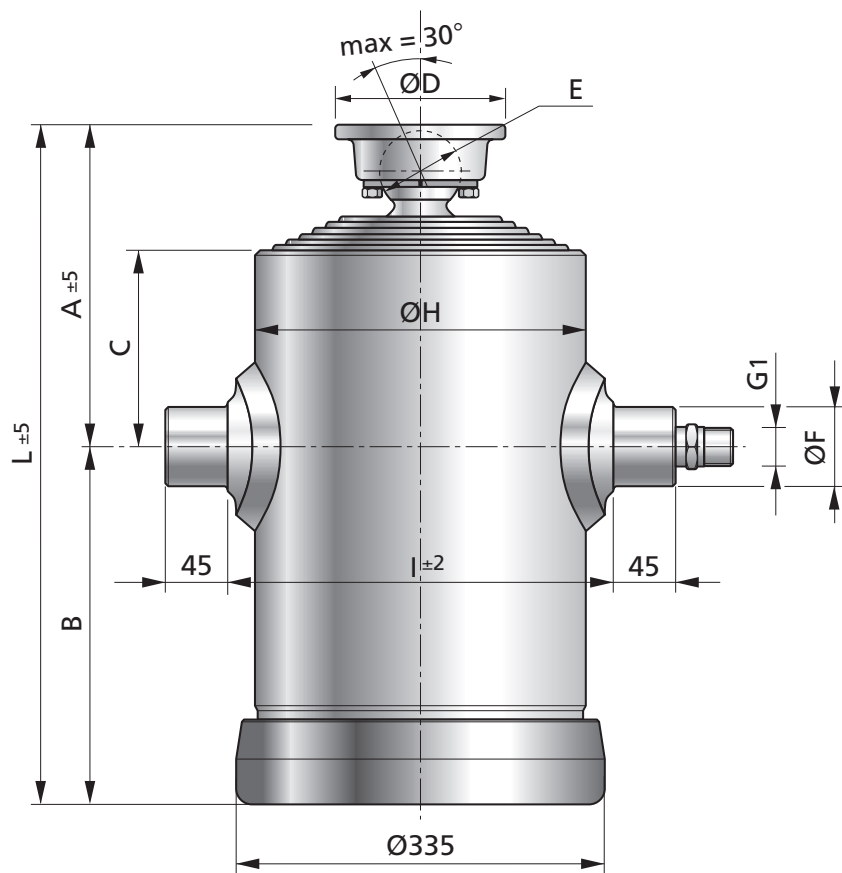

AP 2 • APS 2												
TIPO TYPE TYPE TYP TIPO	SFILATE EXTENSION EXPANSION STUFENZAHL EXPANSION	DIAMETRO - DIAMETER DIAMÈTRE - DURCHMESSER - DIAMETRO [mm]										max SPINTA THRUST POUSSÉE KRAFT EMPUJE [kN]
		I	II	III	IV	V	VI	VII	VIII	IX	X	
AP 2	10	249	221.5	196	174	154	135	116	98	79	61	290
	9	249	221.5	196	174	154	135	116	98	79		346
	8	249	221.5	196	174	154	135	116	98			406
	7	249	221.5	196	174	154	135	116				467
	6	249	221.5	196	174	154	135					495
APS 2	10	249	221.5	196	174	154	135	120	105	90	75	317
	9	249	221.5	196	174	154	135	120	105	90		365
	8	249	221.5	196	174	154	135	120	105			416
	7	249	221.5	196	174	154	135	120				472
	6	249	221.5	196	174	154	135					495

AP 2 • APS 2 DETTAGLI TECNICI TECHNICAL DATA DÉTAIL TECHNIQUES TECHNISCHE DATUM DETALLES TÉCNICOS

ART. NUOVO NEW MODEL NOUVELLE DESCR. NEUE BEZEICHNUNG DESCRIPCION NUEVA	ART. VECCHIO OLD MODEL ANCIENNE DES. ALTE BEZ. DES. ANTIGUA	CODICE CODE CODE BESTELL-Nr. CODIGO	N. SFILATE - EXTENSION N. N. DES BALLONGES STUFENZAHL - N. EXPANSIONES	CORSO - POWER STROKE COURSE DE TRAVAIL GESAMTHUB - CARRERA	MASSA - MASS MASSE - MASSE MASA	OLIO ASSORBITO OIL CONSUMPTION HUILE CONSOMM. ÖLVERBRUCH ACETE ABSORBIDO	PRESSIONE MAX DI LAVORO MAX. WORKING PRESSURE PRESSION DE TRAVAIL MAX. MAXIMUM BETRIEBSDRUCK PRESSION MAX. DE TRABAJO	MASSA TOTALE RIBALTABILE TOTAL MASS TIR-UP MASSE TOTALE REBATABLE GESAMTKIPPMASSSE MASA TOTAL VOLCADA	L	A	B	C	D	E	F	H	I
AP 750 6391 249 10	AP2/750/10	2107502490001	10	6391	363	127.7	250	37.0	922	277	645	140	150	73	70	296	340
AP 750 5751 249 9	AP2/750/9	2107502499001	9	5751	352	125.8	250	44.2	915	270	645	140	150	73	70	296	340
AP 750 5111 249 8	AP2/750/8	2107502498001	8	5111	347	122.7	250	51.7	908	263	645	140	150	73	70	296	340
AP 750 4471 249 7	AP2/750/7	2107502497001	7	4471	339	117.8	250	59.5	929	284	645	140	170	92	70	296	340
AP 750 3833 249 6	AP2/750/6	2107502496001	6	3833	332	111.1	250	68.0	922	277	645	140	170	92	70	296	340
AP 670 5591 249 10	AP2/670/10	2106702490001	10	5591	330	111.7	250	37.0	842	277	565	140	150	73	70	296	340
AP 670 5031 249 9	AP2/670/9	2106702499001	9	5031	318	110.0	250	44.2	835	270	565	140	150	73	70	296	340
AP 670 4471 249 8	AP2/670/8	2106702498001	8	4471	317	107.3	250	51.7	828	263	565	140	150	73	70	296	340
AP 670 3911 249 7	AP2/670/7	2106702497001	7	3911	309	103.1	250	59.5	849	284	565	140	170	92	70	296	340
AP 670 3353 249 6	AP2/670/6	2106702496001	6	3353	302	97.2	250	68.0	842	277	565	140	170	92	70	296	340
AP S565 4600 249 10	APS2/565/10	2205652490001	10	4600	284	93.3	250	40.4	737	255	482	118	150	73	70	296	340
AP S565 4132 249 9	APS2/565/9	2205652499001	9	4132	281	91.2	250	46.5	730	248	482	118	150	73	70	296	340
AP S565 3665 249 8	APS2/565/8	2205652498001	8	3665	277	88.3	250	53.0	723	241	482	118	150	73	70	296	340
AP S565 3198 249 7	APS2/565/7	2205652497001	7	3198	276	84.2	250	60.1	736	254	482	118	170	92	70	296	340
AP S565 2732 249 6	APS2/565/6	2205652496001	6	2732	275	78.9	250	68.0	737	255	482	118	170	92	70	296	340
AP SL 3900 249 10	APSL2/10	22000L2490001	10	3900	255	79.0	250	40.4	667	255	412	118	150	73	70	296	340
AP SL 3502 249 9	APSL2/9	22000L2499001	9	3502	252	77.2	250	46.5	660	248	412	118	150	73	70	296	340
AP SL 3105 249 8	APSL2/8	22000L2498001	8	3105	248	74.7	250	53.0	653	241	412	118	150	73	70	296	340
AP SL 2708 249 7	APSL2/7	22000L2497001	7	2708	248	71.2	250	60.1	666	254	412	118	170	92	70	296	340
AP SL 2312 249 6	APSL2/6	22000L2496001	6	2312	247	66.8	250	68.0	667	255	412	118	170	92	70	296	340
AP S470 3650 249 10	APS2/470/10	2204702490001	10	3650	244	73.8	250	40.4	642	255	387	118	150	73	70	296	340
AP S470 3277 249 9	APS2/470/9	2204702499001	9	3277	242	72.2	250	46.5	635	248	387	118	150	73	70	296	340
AP S470 2905 249 8	APS2/470/8	2204702498001	8	2905	239	69.8	250	53.0	628	241	387	118	150	73	70	296	340
AP S470 2533 249 7	APS2/470/7	2204702497001	7	2533	235	66.6	250	60.1	641	254	387	118	170	92	70	296	340
AP S470 2162 249 6	APS2/470/6	2204702496001	6	2162	234	62.4	250	68.0	642	255	387	118	170	92	70	296	340
AP SH 3123 249 10	APSH2/10	22000H2490001	10	3123	229	65.2	250	40.4	561	237	324	151	150	73	70	296	340
AP SH 2831 249 9	APSH2/9	22000H2499001	9	2831	227	63.9	250	46.5	561	237	324	151	150	73	70	296	340
AP SH 2533 249 8	APSH2/8	22000H2498001	8	2533	224	62.0	250	53.0	561	237	324	151	150	73	70	296	340
AP SH 2228 249 7	APSH2/7	22000H2497001	7	2228	222	59.4	250	60.1	581	257	324	151	170	92	70	296	340
AP SH 1917 249 6	APSH2/6	22000H2496001	6	1917	220	55.8	250	68.0	589	265	324	151	170	92	70	296	340

AP 2 • APS 2

2/2

Accessori
Accessories
Accessoires
Zubehören
Accesorios



SUPPORTO CILINDRO CYLINDER SUPPORT
PALIER VERIN LAGER ZYLINDER
SOPORTE CILINDRO



SUPPORTO BILANCIERE CRADLE SUPPORT
BALANCIER VERIN LAGER KIPPEBEL
SOPORTE CUNA



BILANCIERE CRADLE BALANCIER
KIPPEBEL CUNA



Vedi pagine 26 e 27 per dettagli
See pages 26-27 for details
Voyez pages 26-27 pour détails
Sehen Blatten 26-27 für Informationen
Ver hoias 26-27 para informaciones

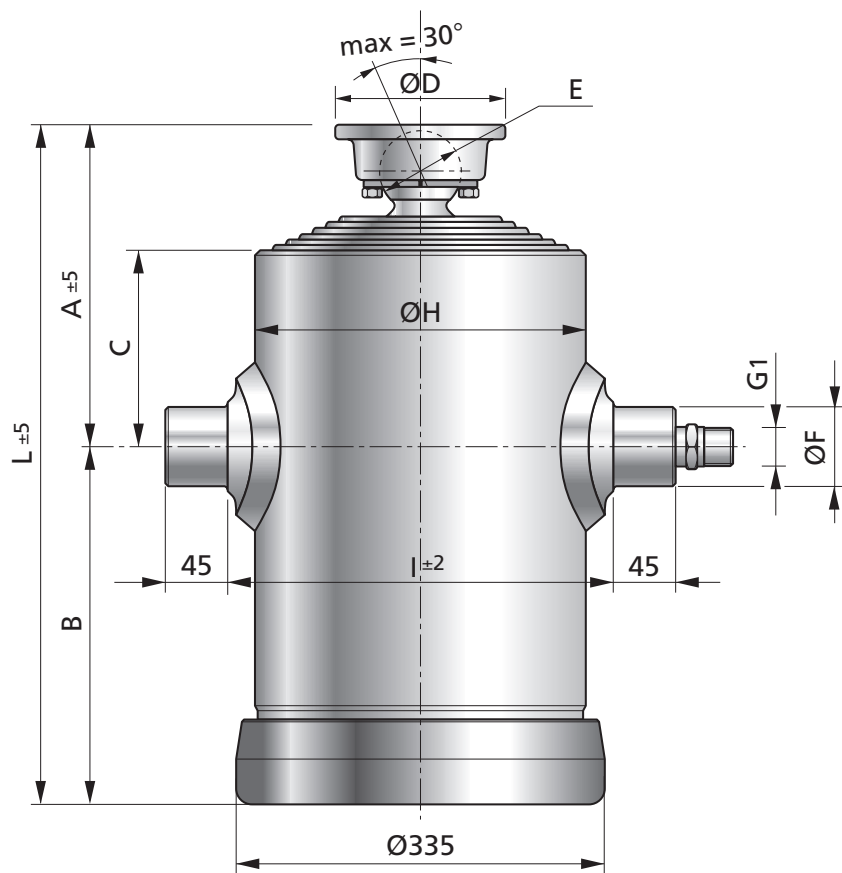

AP 2 • APS 2												
TIPO TYPE TYPE TYP TIPO	SFILATE EXTENSION EXPANSION STUFENZAHL EXPANSION	DIAMETRO - DIAMETER DIAMÈTRE - DURCHMESSER - DIAMETRO [mm]										max SPINTA THRUST POUSSÉE KRAFT EMPUJE [kN]
		I	II	III	IV	V	VI	VII	VIII	IX	X	
AP 2	10	249	221.5	196	174	154	135	116	98	79	61	290
	9	249	221.5	196	174	154	135	116	98	79		346
	8	249	221.5	196	174	154	135	116	98			406
	7	249	221.5	196	174	154	135	116				467
	6	249	221.5	196	174	154	135					495
APS 2	10	249	221.5	196	174	154	135	120	105	90	75	317
	9	249	221.5	196	174	154	135	120	105	90		365
	8	249	221.5	196	174	154	135	120	105			416
	7	249	221.5	196	174	154	135	120				472
	6	249	221.5	196	174	154	135					495

AP 2 • APS 2 DETTAGLI TECNICI TECHNICAL DATA DÉTAIL TECHNIQUES TECHNISCHE DATUM DETALLES TÉCNICOS

ART. NUOVO NEW MODEL NOUVELLE DESCR. NEUE BEZEICHNUNG DESCRIPCION NUEVA	ART. VECCHIO OLD MODEL ANCIENNE DES. ALTE BEZ. DES. ANTIGUA	CODICE CODE CODE BESTELL-Nr. CODIGO	N. SFILATE - EXTENSION N. N. DES RALLONGES N. EXPAISIONES STUFENZAHL - N. EXPAISIONES	CORSO - POWER STROKE COURSE DE TRAVAIL GESAMTHUB - CARRERA	MASSA - MASS MASSE - MASSE MASA	OLIO ASSORBITO OIL CONSUMPTION HUILE CONSOMM. ÖLVERBRAUCH ACEITE ABSORBIDO	PRESSIONE MAX DI LAVORO MAX. WORKING PRESSURE PRESSION DE TRAVAIL MAX. MAXIMUM BETRIEBSDRUCK PRESSION MAX. DE TRABAJO	MASSA TOTALE RIBALTABILE TOTAL MASS TIP-UP MASSE TOTALE REBATABLE GESAMTKIPPMASS MASA TOTAL VOLCADA	L	A	B	C	D	E	F	H	I
AP SM 2908 249 10	APSM2/10	2200AM2490001	10	2908	219	60.9	250	40.4	539	241	298	160	150	73	70	296	340
AP SM 2638 249 9	APSM2/9	2200AM2499001	9	2638	216	59.7	250	46.5	539	241	298	160	150	73	70	296	340
AP SM 2362 249 8	APSM2/8	2200AM2498001	8	2362	215	58.0	250	53.0	539	241	298	160	150	73	70	296	340
AP SM 2079 249 7	APSM2/7	2200AM2497001	7	2079	212	55.5	250	60.1	559	261	298	160	170	92	70	296	340
AP SM 1790 249 6	APSM2/6	2200AM2496001	6	1790	210	52.3	250	68.0	567	269	298	160	170	92	70	296	340
AP SB/A 2716 249 10	APSB2/10A	2200BA2490001	10	2716	210	56.7	250	40.4	521	251	270	160	150	73	70	296	340
AP SB/A 2464 249 9	APSB2/9A	2200BA2499001	9	2464	208	55.6	250	46.5	521	251	270	160	150	73	70	296	340
AP SB/A 2206 249 8	APSB2/8A	2200BA2498001	8	2206	206	53.9	250	53.0	521	251	270	160	150	73	70	296	340
AP SB/A 1941 249 7	APSB2/7A	2200BA2497001	7	1941	207	51.6	250	60.1	541	271	270	160	170	92	70	296	340
AP SB/A 1670 249 6	APSB2/6A	2200BA2496001	6	1670	205	48.6	250	68.0	549	279	270	160	170	92	70	296	340
AP SB 2507 249 10	APSB2/10	22000B2490001	10	2507	195	52.0	250	40.4	492	225	267	128	150	73	70	296	340
AP SB 2270 249 9	APSB2/9	22000B2499001	9	2270	194	50.9	250	46.5	490	223	267	128	150	73	70	296	340
AP SB 2028 249 8	APSB2/8	22000B2498001	8	2028	192	49.4	250	53.0	488	221	267	128	150	73	70	296	340
AP SB 1783 249 7	APSB2/7	22000B2497001	7	1783	193	47.3	250	60.1	506	239	267	128	170	92	70	296	340
AP SB 1532 249 6	APSB2/6	22000B2496001	6	1532	191	44.4	250	68.0	512	245	267	128	170	92	70	296	340
AP SC 2157 249 10	APSC2/10	22000C2490001	10	2157	181	45.1	250	40.4	451	189	262	100	150	73	70	296	340
AP SC 1961 249 9	APSC2/9	22000C2499001	9	1961	180	44.2	250	46.5	451	189	262	100	150	73	70	296	340
AP SC 1758 249 8	APSC2/8	22000C2498001	8	1758	178	42.9	250	53.0	451	189	262	100	150	73	70	296	340
AP SC 1550 249 7	APSC2/7	22000C2497001	7	1550	180	41.1	250	60.1	471	209	262	100	170	92	70	296	340
AP SC 1334 249 6	APSC2/6	22000C2496001	6	1334	179	38.7	250	68.0	479	217	262	100	170	92	70	296	340
AP SCC 1884 249 10	APSCC2/10	2200CC2490001	10	1884	168	39.0	250	40.4	418	202	216	118	150	73	70	296	340
AP SCC 1708 249 9	APSCC2/9	2200CC2499001	9	1708	167	38.2	250	46.5	418	202	216	118	150	73	70	296	340
AP SCC 1525 249 8	APSCC2/8	2200CC2498001	8	1525	166	37.0	250	53.0	418	202	216	118	150	73	70	296	340
AP SCC 1337 249 7	APSCC2/7	2200CC2497001	7	1337	168	35.4	250	60.1	438	222	216	118	170	92	70	296	340
AP SCC 1141 249 6	APSCC2/6	2200CC2496001	6	1141	167	33.2	250	68.0	446	230	216	118	170	92	70	296	340

AP 1 • APS 1

1/2

Accessori
Accessories
Accessoires
Zubehören
Accesorios



SUPPORTO CILINDRO CYLINDER SUPPORT
PALIER VERIN LAGER ZYLINDER
SOPORTE CILINDRO



SUPPORTO BILANCIERE CRADLE SUPPORT
BALANCIER VERIN LAGER KIPPEBEL
SOPORTE CUNA



BILANCIERE CRADLE BALANCIER
KIPPEBEL CUNA



Vedi pagine 26 e 27 per dettagli
See pages 26-27 for details
Voyez pages 26-27 pour détails
Sehen Blatten 26-27 für Informationen
Ver hoias 26-27 para informaciones

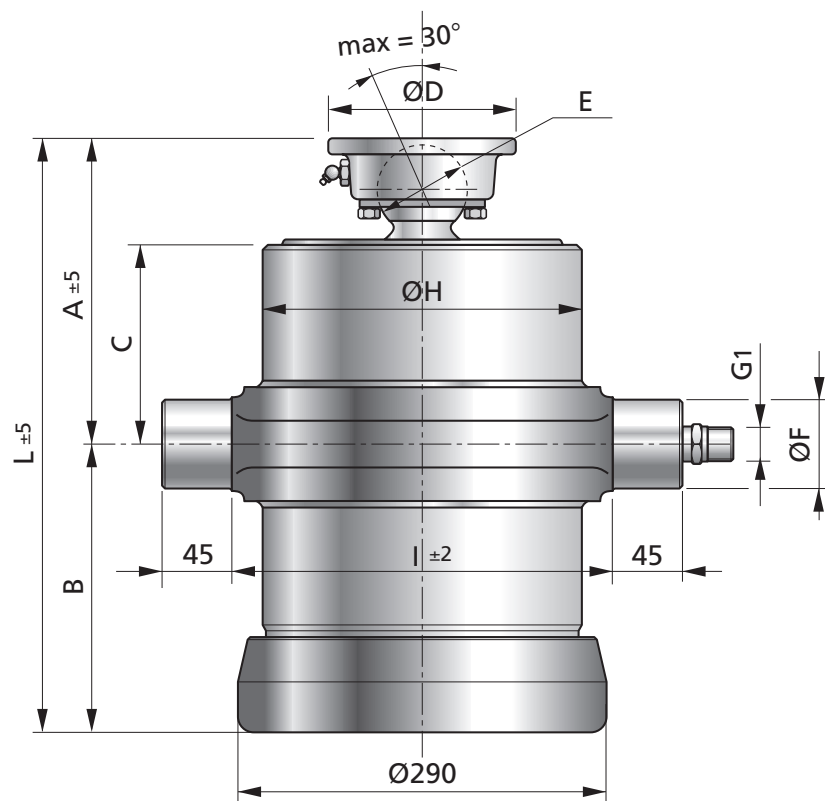

AP 1 • APS 1												
TIPO TYPE TYPE TIPO	SFILATE EXTENSION EXPANSION STUFENZAHL EXPANSION	DIAMETRO - DIAMETER DIAMÈTRE - DURCHMESSER - DIAMETRO [mm]										max SPINTA THRUST POUSSÉE KRAFT EMPUIJE [kN]
		I	II	III	IV	V	VI	VII	VIII	IX	X	
AP 1	9	221.5	196	174	154	135	116	98	79	61		253
	8	221.5	196	174	154	135	116	98	79			304
	7	221.5	196	174	154	135	116	98				358
	6	221.5	196	174	154	135	116					413
APS 1	10	221.5	196	174	154	135	120	105	90	75	60	238
	9	221.5	196	174	154	135	120	105	90	75		279
	8	221.5	196	174	154	135	120	105	90			323
	7	221.5	196	174	154	135	120	105				369
	6	221.5	196	174	154	135	120					418

AP 1 • APS 1 DETTAGLI TECNICI TECHNICAL DATA DÉTAIL TECHNIQUES TECHNISCHE DATUM DETALLES TÉCNICOS

ART. NUOVO NEW MODEL NOUVELLE DESCR. NEUE BEZEICHNUNG DESCRIPCION NUEVA	ART. VECCHIO OLD MODEL ANCIENNE DES. ALTE BEZ. DES. ANTIGUA	CODICE CODE CODE BESTELL-Nr. CODIGO	N. SFILATE - EXTENSION N. N. DES RALLONGES N. EXPAISIONES STUFENZAHL - N. EXPAISIONES	CORSA - POWER STROKE COURSE DE TRAVAIL GESAMTHUB - CARRERA	MASSA - MASS MASSE - MASSE	OLIO ASSORBITO OIL CONSUMPTION HUILE CONSOMM. ÖLVERBRAUCH ACEITE ABSORBIDO	PRESIONE MAX DI LAVORO MAX. WORKING PRESSURE PRESSION DE TRAVAIL MAX. MAXIMUM BETRIEBSDRUCK PRESSION MAX. DE TRABAJO	MASSA TOTALE RIBALTABILE TOTAL MASS TIP-UP MASSE TOTALE REBATABLE GESAMTKIPPMASS MASA TOTAL VOLCADA	L	A	B	C	D	E	F	H	I
								[mm]									
AP 750 5758 221 9	AP1/753/9	2107502219001	9	5758	266	96.9	275	35.5	907	255	652	126	150	73	70	252	300
AP 750 5118 221 8	AP1/753/8	2107502218001	8	5118	254	95.0	275	42.7	900	248	652	126	150	73	70	252	300
AP 750 4478 221 7	AP1/7530/7	2107502217001	7	4478	250	91.9	275	50.2	893	241	652	126	150	73	70	252	300
AP 750 3838 221 6	AP1/753/6	2107502216001	6	3838	238	87.0	275	58.0	886	234	652	126	150	73	70	252	300
AP 670 5038 221 9	AP1/673/9	2106702219001	9	5038	244	84.8	275	35.5	827	255	572	126	150	73	70	252	300
AP 670 4478 221 8	AP1/673/8	2106702218001	8	4478	234	83.1	275	42.7	820	248	572	126	150	73	70	252	300
AP 670 3918 221 7	AP1/673/7	2106702217001	7	3918	233	80.4	275	50.2	813	241	572	126	150	73	70	252	300
AP 670 3358 221 6	AP1/673/6	2106702216001	6	3358	225	76.2	275	58.0	806	234	572	126	150	73	70	252	300
AP S565 4622 221 10	APS1/568/10	2205652210001	10	4622	206	72.9	275	33.4	729	254	475	118	150	73	70	252	300
AP S565 4154 221 9	APS1/568/9	2205652219001	9	4154	197	71.6	275	39.2	722	247	475	118	150	73	70	252	300
AP S565 3687 221 8	APS1/568/8	2205652218001	8	3687	193	69.5	275	45.2	715	240	475	118	150	73	70	252	300
AP S565 3219 221 7	APS1/568/7	2205652217001	7	3219	190	66.6	275	51.7	708	233	475	118	150	73	70	252	300
AP S565 2753 221 6	APS1/568/6	2205652216001	6	2753	187	62.5	275	58.6	701	226	475	118	150	73	70	252	300
AP SL3922 221 10	APSL1/10	22000L2210001	10	3922	186	61.8	275	33.4	659	254	405	118	150	73	70	252	300
AP SL3524 221 9	APSL1/9	22000L2219001	9	3524	177	60.7	275	39.2	652	247	405	118	150	73	70	252	300
AP SL3127 221 8	APSL1/8	22000L2218001	8	3127	174	58.9	275	45.2	645	240	405	118	150	73	70	252	300
AP SL2729 221 7	APSL1/7	22000L2217001	7	2729	171	56.4	275	51.7	638	233	405	118	150	73	70	252	300
AP SL2333 221 6	APSL1/6	22000L2216001	6	2333	170	53.0	275	58.6	631	226	405	118	150	73	70	252	300
AP S470 3672 221 10	APS1/473/10	2204702210001	10	3672	179	57.8	275	33.4	634	254	380	118	150	73	70	252	300
AP S470 3299 221 9	APS1/473/9	2204702219001	9	3299	170	56.8	275	39.2	627	247	380	118	150	73	70	252	300
AP S470 2927 221 8	APS1/473/8	2204702218001	8	2927	167	55.1	275	45.2	620	240	380	118	150	73	70	252	300
AP S470 2554 221 7	APS1/473/7	2204702217001	7	2554	164	52.8	275	51.7	613	233	380	118	150	73	70	252	300
AP S470 2183 221 6	APS1/473/6	2204702216001	6	2183	163	49.5	275	58.6	606	226	380	118	150	73	70	252	300
AP SH 3087 221 10	APSH1/10	22000H2210001	10	3087	167	50.4	275	33.4	546	239	307	158	150	73	70	252	300
AP SH 2802 221 9	APSH1/9	22000H2219001	9	2802	162	49.6	275	39.2	546	239	307	158	150	73	70	252	300
AP SH 2511 221 8	APSH1/8	22000H2218001	8	2511	159	48.3	275	45.2	546	239	307	158	150	73	70	252	300
AP SH 2212 221 7	APSH1/7	22000H2217001	7	2212	157	46.4	275	51.7	546	239	307	158	150	73	70	252	300
AP SH 1908 221 6	APSH1/6	22000H2216001	6	1908	156	43.8	275	58.6	546	239	307	158	150	73	70	252	300
AP SM 2867 221 10	APSM1/10	2200AM2210001	10	2867	155	46.9	275	33.4	524	254	270	173	150	73	70	252	300
AP SM 2604 221 9	APSM1/9	2200AM2219001	9	2604	150	46.2	275	39.2	524	254	270	173	150	73	70	252	300

AP 1 • APS 1

2/2

Accessori
Accessories
Accessoires
Zubehören
Accesorios



SUPPORTO CILINDRO CYLINDER SUPPORT
PALIER VERIN LAGER ZYLINDER
SOPORTE CILINDRO



SUPPORTO BILANCIERE CRADLE SUPPORT
BALANCIER VERIN LAGER KIPPHEBEL
SOPORTE CUNA



BILANCIERE CRADLE BALANCIER
KIPPHEBEL CUNA



Vedi pagine 26 e 27 per dettagli
See pages 26-27 for details
Voyez pages 26-27 pour détails
Sehen Blatten 26-27 für Informationen
Ver hoias 26-27 para informaciones

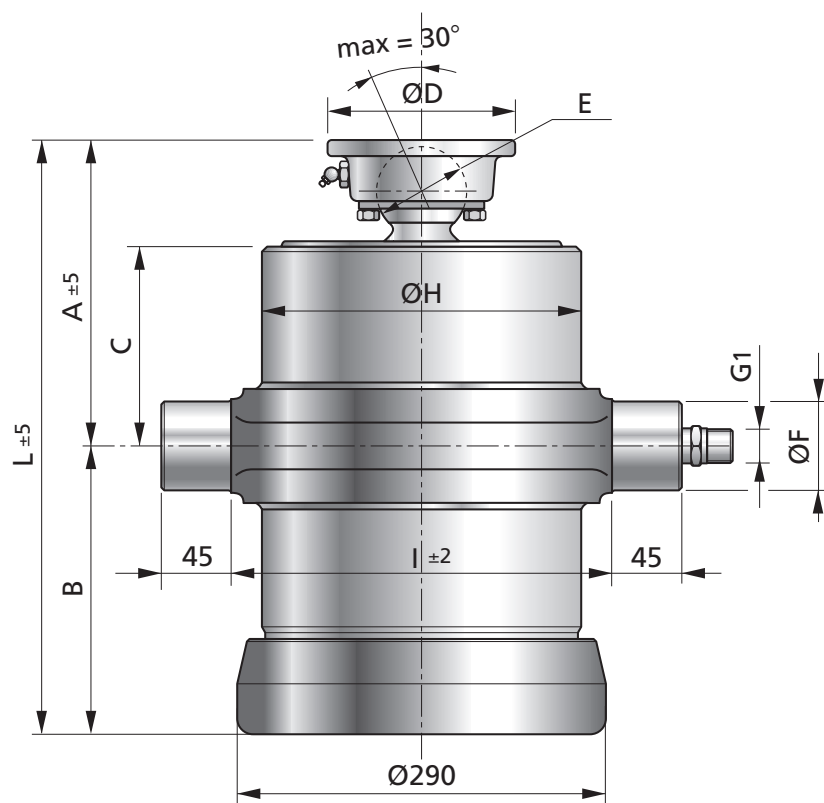

AP 1 • APS 1												
TIPO TYPE TYPE TIPO	SFILATE EXTENSION EXPANSION STUFENZAHL EXPANSION	DIAMETRO - DIAMETER DIAMÈTRE - DURCHMESSER - DIAMETRO [mm]										max SPINTA THRUST POUSSÉE KRAFT EMPUEJE [kN]
		I	II	III	IV	V	VI	VII	VIII	IX	X	
AP 1	9	221.5	196	174	154	135	116	98	79	61		253
	8	221.5	196	174	154	135	116	98	79			304
	7	221.5	196	174	154	135	116	98				358
	6	221.5	196	174	154	135	116					413
APS 1	10	221.5	196	174	154	135	120	105	90	75	60	238
	9	221.5	196	174	154	135	120	105	90	75		279
	8	221.5	196	174	154	135	120	105	90			323
	7	221.5	196	174	154	135	120	105				369
	6	221.5	196	174	154	135	120					418

AP 1 • APS 1 DETTAGLI TECNICI TECHNICAL DATA DÉTAIL TECHNIQUES TECHNISCHE DATUM DETALLES TÉCNICOS

ART. NUOVO NEW MODEL NOUVELLE DESCR. NEUE BEZEICHNUNG DESCRIPCION NUEVA	ART. VECCHIO OLD MODEL ANCIENNE DES. ALTE BEZ. DES. ANTIGUA	CODICE CODE CODE BESTELL-Nr. CODIGO	N. SFILATE - EXTENSION N. N. DES BALLOUES STUFENZAHL - N. EXPANSIONES	CORSO - POWER STROKE COURSE DE TRAVAIL GESAMTHUB - CARRERA	MASSA - MASS MASSE - MASSE	OLIO ASSORBITO OIL CONSUMPTION HUILE CONSONMM. OELVERBRAUCH ACEITE ABSORBIDO	PRESSIONE MAX DI LAVORO MAX. WORKING PRESSURE PRESSION DE TRAVAIL MAX. MAXIMUM BETRIEBSDRUCK PRESSION MAX. DE TRABAJO	MASSA TOTALE RIPALZABILE TOTAL MASS LIFTABLE MASSE TOTALE REBATABLE GESAMTKIPPMASS MASA TOTAL VOLCADA	L	A	B	C	D	E	F	H	I
AP SM 2335 221 8	APSM1/8	2200AM2218001	8	2335	147	45.0	275	45.2	524	254	270	173	150	73	70	252	300
AP SM 2058 221 7	APSM1/7	2200AM2217001	7	2058	146	43.2	275	51.7	524	254	270	173	150	73	70	252	300
AP SM 1776 221 6	APSM1/6	2200AM2216001	6	1776	143	40.8	275	58.6	524	254	270	173	150	73	70	252	300
AP SB/A 2687 221 10	APSB1/10A	2200BA2210001	10	2687	151	44.0	275	33.4	506	254	252	173	150	73	70	252	300
AP SB/A 2442 221 9	APSB1/9A	2200BA2219001	9	2442	145	43.3	275	39.2	506	254	252	173	150	73	70	252	300
AP SB/A 2191 221 8	APSB1/8A	2200BA2218001	8	2191	143	42.2	275	45.2	506	254	252	173	150	73	70	252	300
AP SB/A 1932 221 7	APSB1/7A	2200BA2217001	7	1932	141	40.6	275	51.7	506	254	252	173	150	73	70	252	300
AP SB/A 1668 221 6	APSB1/6A	2200BA2216001	6	1668	140	38.3	275	58.6	506	254	252	173	150	73	70	252	300
AP SB 2493 221 10	APSB1/10	22000B2210001	10	2493	140	40.7	275	33.4	479	249	230	158	150	73	70	252	300
AP SB 2261 221 9	APSB1/9	22000B2219001	9	2261	135	40.0	275	39.2	477	247	230	158	150	73	70	252	300
AP SB 2024 221 8	APSB1/8	22000B2218001	8	2024	133	39.0	275	45.2	475	245	230	158	150	73	70	252	300
AP SB 1782 221 7	APSB1/7	22000B2217001	7	1782	131	37.4	275	51.7	473	243	230	158	150	73	70	252	300
AP SB 1537 221 6	APSB1/6	22000B2216001	6	1537	130	35.3	275	58.6	471	241	230	158	150	73	70	252	300
AP SC 2133 221 10	APSC1/10	22000C2210001	10	2133	130	35.3	275	33.4	436	239	197	158	150	73	70	252	300
AP SC 1944 221 9	APSC1/9	22000C2219001	9	1944	125	34.7	275	39.2	436	239	197	158	150	73	70	252	300
AP SC 1748 221 8	APSC1/8	22000C2218001	8	1748	123	33.9	275	45.2	436	239	197	158	150	73	70	252	300
AP SC 1545 221 7	APSC1/7	22000C2217001	7	1545	122	32.6	275	51.7	436	239	197	158	150	73	70	252	300
AP SC 1337 221 6	APSC1/6	22000C2216001	6	1337	121	30.8	275	58.6	436	239	197	158	150	73	70	252	300
AP SCC 1868 221 10	APSCC1/10	2200CC2210001	10	1868	120	30.4	275	33.4	403	239	164	158	150	73	70	252	300
AP SCC 1699 221 9	APSCC1/9	2200CC2219001	9	1699	116	30.0	275	39.2	403	239	164	158	150	73	70	252	300
AP SCC 1523 221 8	APSCC1/8	2200CC2218001	8	1523	114	29.2	275	45.2	403	239	164	158	150	73	70	252	300
AP SCC 1340 221 7	APSCC1/7	2200CC2217001	7	1340	114	28.0	275	51.7	403	239	164	158	150	73	70	252	300
AP SCC 1152 221 6	APSCC1/6	2200CC2216001	6	1152	113	26.4	275	58.6	403	239	164	158	150	73	70	252	300

AP 01 • APS 01

1/2

Accessori
Accessories
Accessoires
Zubehören
Accesorios



SUPPORTO CILINDRO CYLINDER SUPPORT
PALIER VERIN LAGER ZYLINDER
SOPORTE CILINDRO



SUPPORTO BILANCIERE CRADLE SUPPORT
BALANCIER VERIN LAGER KIPPHEBEL
SOPORTE CUNA



BILANCIERE CRADLE BALANCIER
KIPPHEBEL CUNA



Vedi pagine 26 e 27 per dettagli
See pages 26-27 for details
Voyez pages 26-27 pour détails
Sehen Blättern 26-27 für Informationen
Ver hoias 26-27 para informaciones

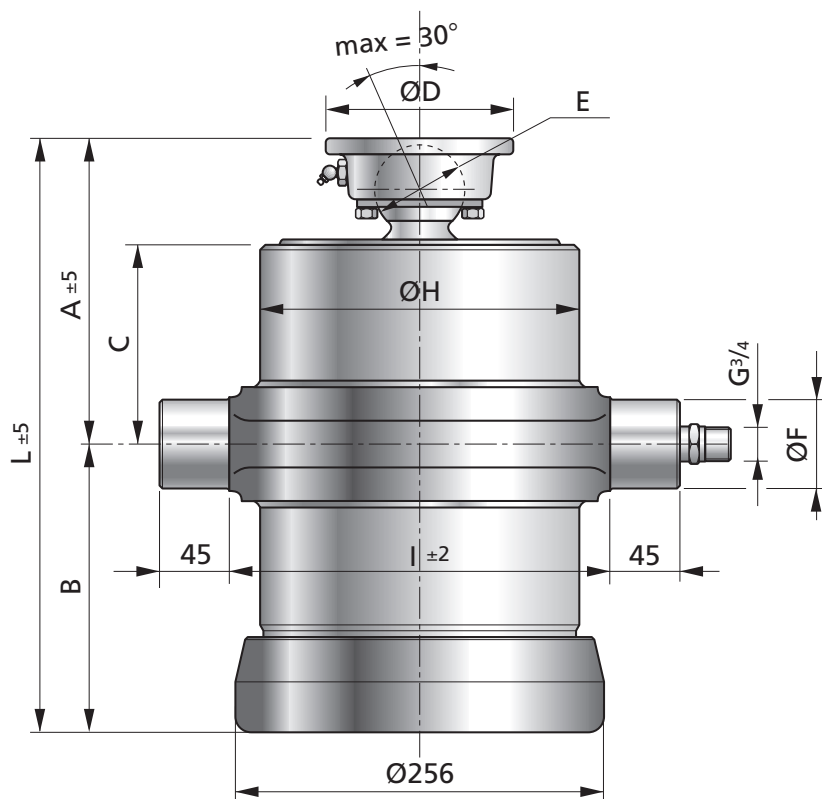

AP 01 • APS 01												
TIPO TYPE TYP TIPO	SFILATE EXTENSION EXPANSION STUFENZAHL EXPANSION	DIAMETRO - DIAMETER DIAMÈTRE - DURCHMESSER - DIAMETRO [mm]										max SPINTA THRUST POUSSEE KRAFT EMPUJE [kN]
		I	II	III	IV	V	VI	VII	VIII	IX	X	
AP 01	8	196	174	154	135	116	98	79	61			221
	7	196	174	154	135	116	98	79				267
	6	196	174	154	135	116	98					315
	5	196	174	154	135	116						365
APS01	10	196	174	154	135	120	105	90	75	60	45	173
	9	196	174	154	135	120	105	90	75	60		209
	8	196	174	154	135	120	105	90	75			246
	7	196	174	154	135	120	105	90				285
	6	196	174	154	135	120	105					326
	5	196	174	154	135	120						370

AP 01 • APS 01 DETTAGLI TECNICI TECHNICAL DATA DÉTAIL TECHNIQUES TECHNISCHE DATUM DETALLES TÉCNICOS

ART. NUOVO NEW MODEL NOUVELLE DESCR. NEUE BEZEICHNUNG DESCRIPCION NUEVA	ART. VECCHIO OLD MODEL ANCIENNE DES. ALTE BEZ. DES. ANTIGUA	CODICE CODE CODE BESTELL-Nr. CODIGO	N. SFILATE - EXTENSION N. N. DES RALLONGES STUFENZAHL - N. EXPANSIONES	CORSA - POWER STROKE COURSE DE TRAVAIL GESAMTHUB - CARRERA	MASSA - MASS MASSE - MASSE MASSE	OIL CONSUMPTION HUILE CONSOMM OELVERBRUCH ACEITE ABSORBIDO	PRESIONE MAX DI LAVORO MAX. WORKING PRESSURE PRESSION DE TRAVAIL MAX. MAXIMUM BETRIEBSDRUCK PRESION MAX. DE TRABAJO	TOTAL MASS TIP-UP MASSE TOTALE REBATABLE GESAMTKIPPMASSE MASA TOTAL VOLCADA	L	A	B	C	D	E	F	H	I
								[mm]									
AP 750 5120 196 8	AP01/753/8	2107501968001	8	5120	218	72.3	275	30.9	901	255	646	131	150	73	55	225	255
AP 750 4480 196 7	AP01/753/7	2107501967001	7	4480	209	70.4	275	37.4	894	248	646	131	150	73	55	225	255
AP 750 3840 196 6	AP01/753/6	2107501966001	6	3840	196	67.3	275	44.2	887	241	646	131	150	73	55	225	255
AP 750 3200 196 5	AP01/753/5	2107501965001	5	3200	185	62.4	275	51.2	880	234	646	131	150	73	55	225	255
AP 670 4480 196 8	AP01/673/8	2106701968001	8	4480	183	63.3	275	30.9	821	255	566	131	150	73	55	225	255
AP 670 3920 196 7	AP01/673/7	2106701967001	7	3920	175	61.6	275	37.4	814	248	566	131	150	73	55	225	255
AP 670 3360 196 6	AP01/673/6	2106701966001	6	3360	171	58.9	275	44.2	807	241	566	131	150	73	55	225	255
AP 670 2800 196 5	AP01/673/5	2106701965001	5	2800	165	54.6	275	51.2	800	234	566	131	150	73	55	225	255
AP S565 4170 196 9	APS01/568/9	2205651969001	9	4170	159	55.5	275	29.3	723	249	474	118	150	73	55	225	255
AP S565 3703 196 8	APS01/568/8	2205651968001	8	3703	154	54.2	275	34.5	716	242	474	118	150	73	55	225	255
AP S565 3235 196 7	APS01/568/7	2205651967001	7	3235	151	52.1	275	40.0	709	235	474	118	150	73	55	225	255
AP S565 2768 196 6	APS01/568/6	2205651966001	6	2768	147	49.2	275	45.7	702	228	474	118	150	73	55	225	255
AP S565 2301 196 5	APS01/568/5	2205651965001	5	2301	145	45.1	275	51.9	695	221	474	118	150	73	55	225	255
AP SL 3540 196 9	APSL01/9	22000L1969001	9	3540	144	47.1	275	29.3	653	249	404	118	150	73	55	225	255
AP SL 3143 196 8	APSL01/8	22000L1968001	8	3143	139	46.0	275	34.5	646	242	404	118	150	73	55	225	255
AP SL 2745 196 7	APSL01/7	22000L1967001	7	2745	136	44.2	275	40.0	639	235	404	118	150	73	55	225	255
AP SL 2348 196 6	APSL01/6	22000L1966001	6	2348	132	41.7	275	45.7	632	228	404	118	150	73	55	225	255
AP SL 1951 196 5	APSL01/5	22000L1965001	5	1951	131	38.3	275	51.9	625	221	404	118	150	73	55	225	255
AP S470 3315 196 9	APS01/473/9	2204701969001	9	3315	142	44.1	275	29.3	628	249	379	118	150	73	55	225	255
AP S470 2943 196 8	APS01/473/8	2204701968001	8	2943	133	43.0	275	34.5	621	242	379	118	150	73	55	225	255
AP S470 2570 196 7	APS01/473/7	2204701967001	7	2570	131	41.4	275	40.0	614	235	379	118	150	73	55	225	255
AP S470 2198 196 6	APS01/473/6	2204701966001	6	2198	127	39.0	275	45.7	607	228	379	118	150	73	55	225	255
AP S470 1826 196 5	APS01/473/5	2204701965001	5	1826	125	35.8	275	51.9	600	221	379	118	150	73	55	225	255
AP SH 2763 196 9	APSH01/9	22000H1969001	9	2763	133	37.9	275	29.3	540	239	301	158	150	73	55	225	255
AP SH 2479 196 8	APSH01/8	22000H1968001	8	2479	128	37.1	275	34.5	540	239	301	158	150	73	55	225	255
AP SH 2187 196 7	APSH01/7	22000H1967001	7	2187	126	35.8	275	40.0	540	239	301	158	150	73	55	225	255
AP SH 1889 196 6	APSH01/6	22000H1966001	6	1889	125	33.9	275	45.7	540	239	301	158	150	73	55	225	255
AP SH 1584 196 5	APSH01/5	22000H1965001	5	1584	123	31.3	275	51.9	540	239	301	158	150	73	55	225	255
AP SM 2821 196 10	APSM01/10	2200AM1960001	10	2821	126	35.7	275	24.3	509	241	268	169	120	58	55	225	255
AP SM 2565 196 9	APSM01/9	2200AM1969001	9	2565	122	35.3	275	29.3	518	250	268	169	150	73	55	225	255

AP 01 • APS 01

2/2

Accessori
Accessories
Accessoires
Zubehören
Accesorios



SUPPORTO CILINDRO CYLINDER SUPPORT
PALIER VERIN LAGER ZYLINDER
SOPORTE CILINDRO



SUPPORTO BILANCIERE CRADLE SUPPORT
BALANCIER VERIN LAGER KIPPEBEL
SOPORTE CUNA



BILANCIERE CRADLE BALANCIER
KIPPEBEL CUNA



Vedi pagine 26 e 27 per dettagli
See pages 26-27 for details
Voyez pages 26-27 pour détails
Sehen Blatten 26-27 für Informationen
Ver hoias 26-27 para informaciones

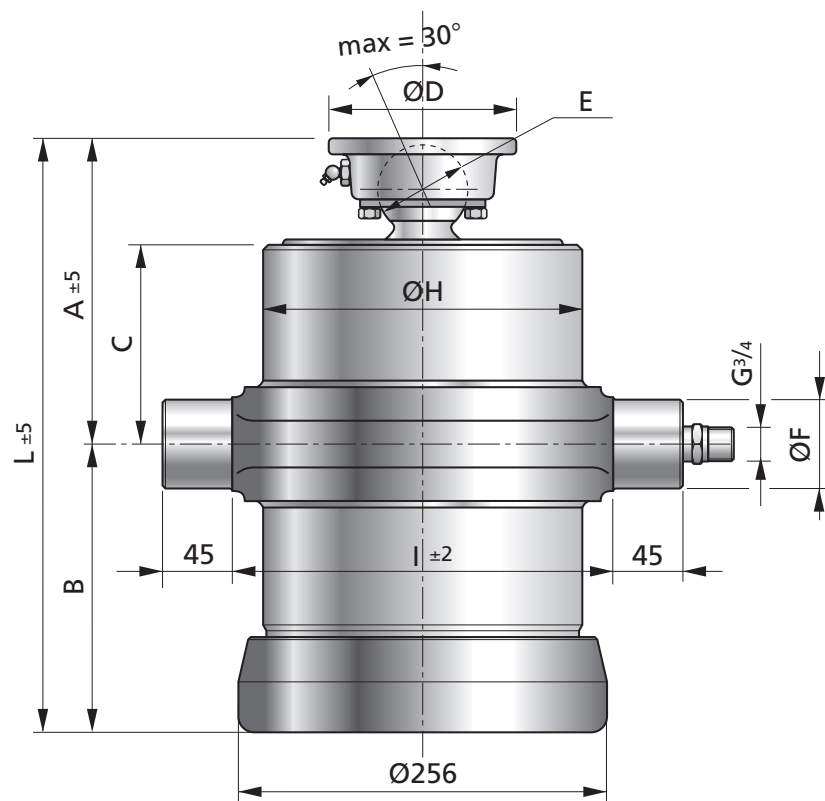

AP 01 • APS 01												
TIPO TYPE TYP TIPO	SFILATE EXTENSION EXPANSION STUFENZAHL EXPANSION	DIAMETRO - DIAMETER DIAMÈTRE - DURCHMESSER - DIAMETRO [mm]										max SPINTA THRUST POUSÉE KRAFT EMPUJE [kN]
		I	II	III	IV	V	VI	VII	VIII	IX	X	
AP 01	8	196	174	154	135	116	98	79	61			221
	7	196	174	154	135	116	98	79				267
	6	196	174	154	135	116	98					315
	5	196	174	154	135	116						365
APS01	10	196	174	154	135	120	105	90	75	60	45	173
	9	196	174	154	135	120	105	90	75	60		209
	8	196	174	154	135	120	105	90	75			246
	7	196	174	154	135	120	105	90				285
	6	196	174	154	135	120	105					326
	5	196	174	154	135	120						370

AP 01 • APS 01 DETTAGLI TECNICI TECHNICAL DATA DÉTAIL TECHNIQUES TECHNISCHE DATUM DETALLES TÉCNICOS

ART. NUOVO NEW MODEL NOUVELLE DESCR. NEUE BEZEICHNUNG DESCRIPCION NUEVA	ART. VECCHIO OLD MODEL ANCIENNE DES. ALTE BEZ. DES. ANTIGUA	CODICE CODE CODE BESTELL-Nr. CODIGO	N. SFILATE - EXTENSION N. N. DES RALLONGES N. EXPAISIONES STUFENZAHL - N. EXPAISIONES	CORSO - POWER STROKE COURSE DE TRAVAIL GESAMTHUB - CARRERA	MASSA - MASS MASSE - MASSE	OLIO ASSORBITO OIL CONSUMPTION HUILE CONSUMM. ÖLVERBRAUCH ACEITE ABSORBIDO	PRESSIONE MAX DI LAVORO MAX. WORKING PRESSURE PRESSION DE TRAVAIL MAX. MAXIMUM BETRIEBSDRUCK PRESSION MAX. DE TRABAJO	MASSA TOTALE RIBALTABILE TOTAL MASS TIP-UP MASSE TOTALE REBATABLE GESAMTKIPPMASS MASA TOTAL VOLCADA	L	A	B	C	D	E	F	H	I
									[mm]	[kg]	[dm ³]	[bar]	[ton]	[mm]			
AP SM 2303 196 8	APSM01/8	2200AM1968001	8	2303	116	34.5	275	34.5	518	250	268	169	150	73	55	225	255
AP SM 2033 196 7	APSM01/7	2200AM1967001	7	2033	113	33.3	275	40.0	518	250	268	169	150	73	55	225	255
AP SM 1757 196 6	APSM01/6	2200AM1966001	6	1757	112	31.6	275	45.7	518	250	268	169	150	73	55	225	255
AP SM 1474 196 5	APSM01/5	2200AM1965001	5	1474	109	29.1	275	51.9	518	250	268	169	150	73	55	225	255
AP SB/A 2641 196 10	APSB01/10A	2200BA1960001	10	2641	121	33.5	275	24.3	491	241	250	169	120	58	55	225	255
AP SB/A 2403 196 9	APSB01/9A	2200BA1969001	9	2403	119	33.1	275	29.3	500	250	250	169	150	73	55	225	255
AP SB/A 2159 196 8	APSB01/8A	2200BA1968001	8	2159	113	32.4	275	34.5	500	250	250	169	150	73	55	225	255
AP SB/A 1907 196 7	APSB01/7A	2200BA1967001	7	1907	111	31.3	275	40.0	500	250	250	169	150	73	55	225	255
AP SB/A 1649 196 6	APSB01/6A	2200BA1966001	6	1649	109	29.7	275	45.7	500	250	250	169	150	73	55	225	255
AP SB/A 1384 196 5	APSB01/5A	2200BA1965001	5	1384	108	27.4	275	51.9	500	250	250	169	150	73	55	225	255
AP SB 2462 196 10	APSB01/10	2200B1960001	10	2462	112	31.0	275	24.3	466	242	224	158	120	58	55	225	255
AP SB 2232 196 9	APSB01/9	2200B1969001	9	2232	110	30.6	275	29.3	473	249	224	158	150	73	55	225	255
AP SB 2000 196 8	APSB01/8	2200B1968001	8	2000	105	29.9	275	34.5	471	247	224	158	150	73	55	225	255
AP SB 1763 196 7	APSB01/7	2200B1967001	7	1763	103	28.9	275	40.0	469	245	224	158	150	73	55	225	255
AP SB 1521 196 6	APSB01/6	2200B1966001	6	1521	100	27.4	275	45.7	467	243	224	158	150	73	55	225	255
AP SB 1276 196 5	APSB01/5	2200B1965001	5	1276	100	25.2	275	51.9	465	241	224	158	150	73	55	225	255
AP SC 2090 196 10	APSC01/10	2200C1960001	10	2090	104	26.8	275	24.3	421	230	191	158	120	58	55	225	255
AP SC 1905 196 9	APSC01/9	2200C1969001	9	1905	102	26.5	275	29.3	430	239	191	158	150	73	55	225	255
AP SC 1716 196 8	APSC01/8	2200C1968001	8	1716	97	25.9	275	34.5	430	239	191	158	150	73	55	225	255
AP SC 1520 196 7	APSC01/7	2200C1967001	7	1520	95	25.1	275	40.0	430	239	191	158	150	73	55	225	255
AP SC 1317 196 6	APSC01/6	2200C1966001	6	1317	94	23.8	275	45.7	430	239	191	158	150	73	55	225	255
AP SC 1109 196 5	APSC01/5	2200C1965001	5	1109	94	22.0	275	51.9	430	239	191	158	150	73	55	225	255
AP SCC 1838 196 10	APSCC01/10	2200CC1960001	10	1838	95	23.2	275	24.3	388	230	158	158	120	58	55	225	255
AP SCC 1673 196 9	APSCC01/9	2200CC1969001	9	1673	94	22.9	275	29.3	397	239	158	158	150	73	55	225	255
AP SCC 1504 196 8	APSCC01/8	2200CC1968001	8	1504	90	22.5	275	34.5	397	239	158	158	150	73	55	225	255
AP SCC 1328 196 7	APSCC01/7	2200CC1967001	7	1328	88	21.7	275	40.0	397	239	158	158	150	73	55	225	255
AP SCC 1145 196 6	APSCC01/6	2200CC1966001	6	1145	87	20.5	275	45.7	397	239	158	158	150	73	55	225	255
AP SCC 957 196 5	APSCC01/5	2200CC1965001	5	957	86	18.9	275	51.9	397	239	158	158	150	73	55	225	255

AP 02 • APS 02

1/2

Accessori
Accessories
Accessoires
Zubehören
Accesorios



SUPPORTO CILINDRO CYLINDER SUPPORT
PALIER VERIN LAGER ZYLINDER
SOPORTE CILINDRO



SUPPORTO BILANCIERE CRADLE SUPPORT
BALANCIER VERIN LAGER KIPPEBEL
SOPORTE CUNA



BILANCIERE CRADLE BALANCIER
KIPPEBEL CUNA



Vedi pagine 26 e 27 per dettagli
See pages 26-27 for details
Voyez pages 26-27 pour détails
Sehen Blatten 26-27 für Informationen
Ver hoias 26-27 para informaciones

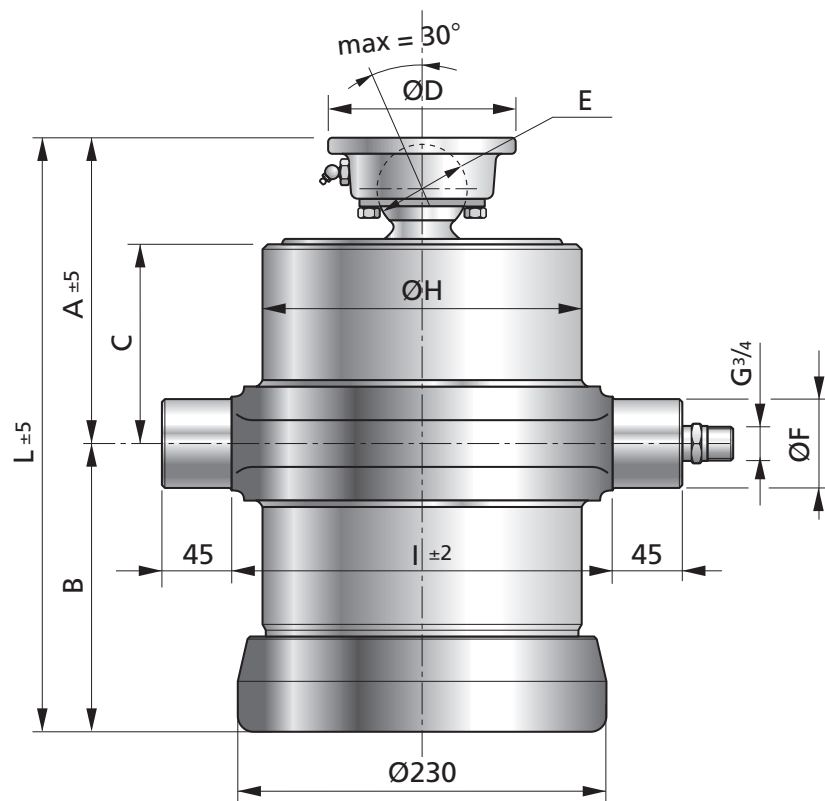

AP 02 • APS 02											
TIPO TYPE TYP TIPO	SFILATE EXTENSION EXPANSION STUFENZAHL EXPANSION	DIAMETRO - DIAMETER DIAMÈTRE - DURCHMESSER - DIAMETRO [mm]									max SPINTA THRUST POUSSEE KRAFT EMPUJE [kN]
		I	II	III	IV	V	VI	VII	VIII	IX	
AP 02	7	174	154	135	116	98	79	61			191
	6	174	154	135	116	98	79				233
	5	174	154	135	116	98					277
APS02	9	174	154	135	120	105	90	75	60	45	151
	8	174	154	135	120	105	90	75	60		175
	7	174	154	135	120	105	90	75			217
	6	174	154	135	120	105	90				251
	5	174	154	135	120	105					288

AP 02 • APS 02 DETTAGLI TECNICI TECHNICAL DATA DÉTAIL TECHNIQUES TECHNISCHE DATUM DETALLES TÉCNICOS

ART. NUOVO NEW MODEL NOUVELLE DESCR. NEUE BEZEICHNUNG DESCRIPCION NUEVA	ART. VECCHIO OLD MODEL ANCIENNE DES. ALTE BEZ. DES. ANTIGUA	CODICE CODE CODE BESTELL-Nr. CODIGO	N. SFILATE - EXTENSION N. N. DES BALLONNES STUFENZAHL - N. EXPANSIONES	CORSA - POWER STROKE COURSE DE TRAVAIL GESAMTHUB - CARRERA	MASSA - MASS MASSE - MASSE	OLIO ASSORBITO OIL CONSUMPTION HUILE CONSOMM. ÖLVERBRAUCH ACEITE ABSORBIDO	PRESIONE MAX DI LAVORO MAX. WORKING PRESSURE PRESSION DE TRAVAIL MAX. MAXIMUM BETRIEBSDRUCK PRESSION MAX. DE TRABAJO	MASSA TOTALE RIBALTABILE TOTAL MASS TIP-UP MASSE TOTALE REBATABLE GESAMTKIPPMASSSE MASA TOTAL VOLCADA	L	A	B	C	D	E	F	H	I
								[mm]									
AP 750 4476 1747	AP02/753/7	2107501747001	7	4476	168	52.8	300	33.7	894	255	639	136	150	73	55	198	238
AP 750 3836 1746	AP02/753/6	2107501746001	6	3836	155	51.0	300	40.8	887	248	639	136	150	73	55	198	238
AP 750 3196 1745	AP02/753/5	2107501745001	5	3196	143	47.8	300	48.2	880	241	639	136	150	73	55	198	238
AP 670 3916 1747	AP02/673/7	2106701747001	7	3916	143	46.2	300	33.7	814	255	559	136	150	73	55	198	238
AP 670 3356 1746	AP02/673/6	2106701746001	6	3356	135	44.6	300	40.8	807	248	559	136	150	73	55	198	238
AP 670 2796 1745	AP02/673/5	2106701745001	5	2796	131	41.9	300	48.2	800	241	559	136	150	73	55	198	238
AP S565 3713 1748	APS02/568/8	2205651748001	8	3713	128	41.7	300	28.0	707	235	472	118	120	58	55	198	238
AP S565 3246 1747	APS02/568/7	2205651747001	7	3246	120	40.4	300	33.1	709	237	472	118	150	73	55	198	238
AP S565 2778 1746	APS02/568/6	2205651746001	6	2778	116	38.4	300	38.5	702	230	472	118	150	73	55	198	238
AP S565 2311 1745	APS02/568/5	2205651745001	5	2311	113	35.4	300	44.1	695	223	472	118	150	73	55	198	238
AP SL 3153 1748	APSL02/8	22000L1748001	8	3153	115	35.4	300	28.0	637	235	402	118	120	58	55	198	238
AP SL 2756 1747	APSL02/7	22000L1747001	7	2756	109	34.3	300	33.1	639	237	402	118	150	73	55	198	238
AP SL 2358 1746	APSL02/6	22000L1746001	6	2358	105	32.5	300	38.5	632	230	402	118	150	73	55	198	238
AP SL 1961 1745	APSL02/5	22000L1745001	5	1961	102	30.0	300	44.1	625	223	402	118	150	73	55	198	238
AP S470 2953 1748	APS02/473/8	2204701748001	8	2953	111	33.2	300	28.0	612	235	377	118	120	58	55	198	238
AP S470 2581 1747	APS02/473/7	2204701747001	7	2581	105	32.1	300	33.1	614	237	377	118	150	73	55	198	238
AP S470 2208 1746	APS02/473/6	2204701746001	6	2208	101	30.5	300	38.5	607	230	377	118	150	73	55	198	238
AP S470 1836 1745	APS02/473/5	2204701745001	5	1836	99	28.1	300	44.1	600	223	377	118	150	73	55	198	238
AP SH 2439 1748	ASH02/8	22000H1748001	8	2439	100	28.1	300	28.0	524	230	294	158	120	58	55	198	238
AP SH 2155 1747	APSH02/7	22000H1747001	7	2155	95	27.3	300	33.1	533	239	294	158	150	73	55	198	238
AP SH 1863 1746	APSH02/6	22000H1746001	6	1863	92	26.1	300	38.5	533	239	294	158	150	73	55	198	238
AP SH 1565 1745	APSH02/5	22000H1745001	5	1565	89	24.2	300	44.1	533	239	294	158	150	73	55	198	238
AP SM 2519 1749	APSM02/9	2200AM1749001	9	2519	96	26.6	300	23.1	502	230	272	158	120	58	55	198	238
AP SM 2263 1748	APSM02/8	2200AM1748001	8	2263	91	26.2	300	28.0	502	230	272	158	120	58	55	198	238
AP SM 2001 1747	APSM02/7	2200AM1747001	7	2001	86	25.4	300	33.1	511	239	272	158	150	73	55	198	238
AP SM 1731 1746	APSM02/6	2200AM1746001	6	1731	83	24.2	300	38.5	511	239	272	158	150	73	55	198	238
AP SM 1455 1745	APSM02/5	2200AM1745001	5	1455	82	22.5	300	44.1	511	239	272	158	150	73	55	198	238
AP SB/A 2357 1749	APSB02/9A	2200BA1749001	9	2357	94	24.9	300	23.1	484	230	254	158	120	58	55	198	238
AP SB/A 2119 1748	APSB02/8A	2200BA1748001	8	2119	92	24.5	300	28.0	484	230	254	158	120	58	55	198	238
AP SB/A 1875 1747	APSB02/7A	2200BA1747001	7	1875	89	23.8	300	33.1	493	239	254	158	150	73	55	198	238

AP 02 • APS 02

2/2

Accessori
Accessories
Accessoires
Zubehören
Accesorios



SUPPORTO CILINDRO CYLINDER SUPPORT
PALIER VERIN LAGER ZYLINDER
SOPORTE CILINDRO



SUPPORTO BILANCIERE CRADLE SUPPORT
BALANCIER VERIN LAGER KIPHEBEL
SOPORTE CUNA



BILANCIERE CRADLE BALANCIER
KIPHEBEL CUNA



Vedi pagine 26 e 27 per dettagli
See pages 26-27 for details
Voyez pages 26-27 pour détails
Sehen Blatten 26-27 für Informationen
Ver hoias 26-27 para informaciones

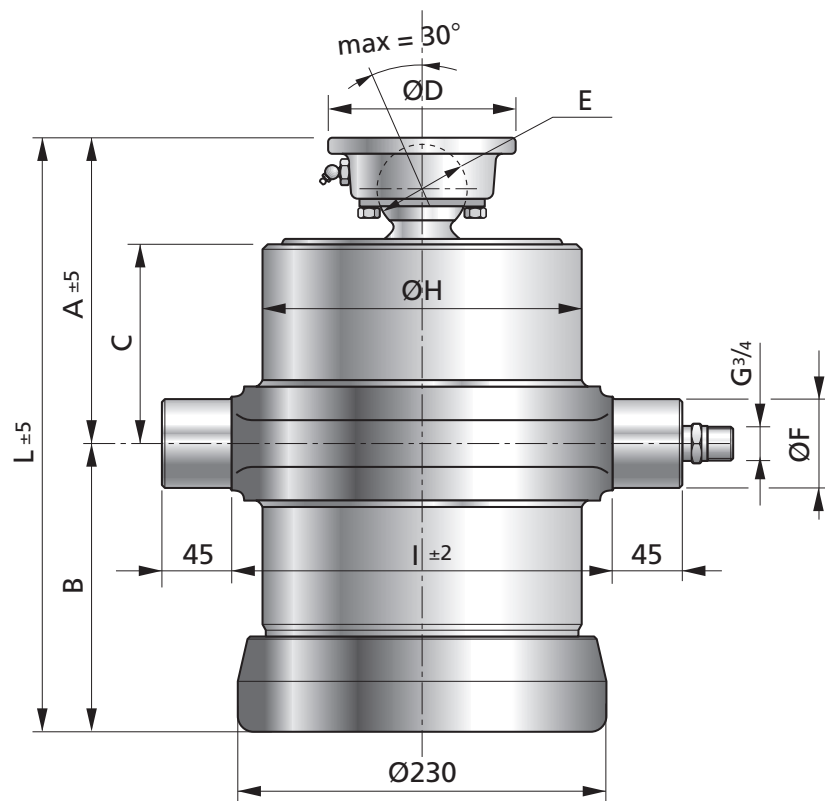

AP 02 • APS 02											
TIPO TYPE TYP TIPO	SFILATE EXTENSION EXPANSION STUFENZAHL EXPANSION	DIAMETRO - DIAMETER DIAMÈTRE - DURCHMESSER - DIAMETRO [mm]									max SPINTA THRUST POUSSEE KRAFT EMPUEJE [kN]
		I	II	III	IV	V	VI	VII	VIII	IX	
AP 02	7	174	154	135	116	98	79	61			191
	6	174	154	135	116	98	79				233
	5	174	154	135	116	98					277
APS02	9	174	154	135	120	105	90	75	60	45	151
	8	174	154	135	120	105	90	75	60		175
	7	174	154	135	120	105	90	75			217
	6	174	154	135	120	105	90				251
	5	174	154	135	120	105					288

AP 02 • APS 02 DETTAGLI TECNICI TECHNICAL DATA DÉTAIL TECHNIQUES TECHNISCHE DATUM DETALLES TÉCNICOS

ART. NUOVO NEW MODEL NOUVELLE DESCR. NEUE BEZEICHNUNG DESCRIPCION NUEVA	ART. VECCHIO OLD MODEL ANCIENNE DES. ALTE BEZ. DES. ANTIGUA	CODICE CODE CODE BESTELL-Nr. CODIGO	N. SFILATE - EXTENSION N. N. DES BALLONNES N. EXPANSIONES STUFENZAHL - N. EXPANSIONES	CORSA - POWER STROKE COURSE DE TRAVAIL GESAMTHUB - CARRERA	MASSA - MASS MASSE - MASSE MASA	OLIO ASSORBITO OIL CONSUMPTION HUILE CONSOMM. ÖLVERBRAUCH ACEITE ABSORBIDO	PRESIONE MAX DI LAVORO MAX. WORKING PRESSURE PRESSION DE TRAVAIL MAX. MAXIMUM BETRIEBSDRUCK PRESSION MAX. DE TRABAJO	MASSA TOTALE RIBALTABILE TOTAL MASS TIP-UP MASSE TOTALE REBATABLE GESAMTKIPPMASSSE MASA TOTAL VOLCADA	L	A	B	C	D	E	F	H	I
								[mm]									
APSB/A 1623 1746	APSB02/6A	2200BA1746001	6	1623	86	22.7	300	38.5	493	239	254	158	150	73	55	198	238
APSB/A 1365 1745	APSB02/5A	2200BA1745001	5	1365	83	21.1	300	44.1	493	239	254	158	150	73	55	198	238
APSB 2200 1749	APSB02/9	22000B1749001	9	2200	87	23.1	300	23.1	459	242	217	158	120	58	55	198	238
APSB 1971 1748	APSB02/8	22000B1748001	8	1971	85	22.7	300	28.0	457	240	217	158	120	58	55	198	238
APSB 1739 1747	APSB02/7	22000B1747001	7	1739	83	22.1	300	33.1	464	247	217	158	150	73	55	198	238
APSB 1502 1746	APSB02/6	22000B1746001	6	1502	80	21.0	300	38.5	462	245	217	158	150	73	55	198	238
APSB 1260 1745	APSB02/5	22000B1745001	5	1260	78	19.5	300	44.1	460	243	217	158	150	73	55	198	238
APSC 1861 1749	APSC02/9	22000C1749001	9	1861	81	19.9	300	23.1	414	230	184	158	120	58	55	198	238
APSC 1677 1748	APSC02/8	22000C1748001	8	1677	79	19.6	300	28.0	414	230	184	158	120	58	55	198	238
APSC 1488 1747	APSC02/7	22000C1747001	7	1488	77	19.0	300	33.1	423	239	184	158	150	73	55	198	238
APSC 1292 1746	APSC02/6	22000C1746001	6	1292	75	18.2	300	38.5	423	239	184	158	150	73	55	198	238
APSC 1089 1745	APSC02/5	22000C1745001	5	1089	73	16.9	300	44.1	423	239	184	158	150	73	55	198	238
APSCC 1642 1749	APSCC02/9	2200CC1749001	9	1642	74	17.3	300	23.1	381	230	151	158	120	58	55	198	238
APSCC 1478 1748	APSCC02/8	2200CC1748001	8	1478	73	17.0	300	28.0	381	230	151	158	120	58	55	198	238
APSCC 1309 1747	APSCC02/7	2200CC1747001	7	1309	72	16.6	300	33.1	390	239	151	158	150	73	55	198	238
APSCC 1133 1746	APSCC02/6	2200CC1746001	6	1133	70	15.8	300	38.5	390	239	151	158	150	73	55	198	238
APSCC 950 1745	APSCC02/5	2200CC1745001	5	950	68	14.6	300	44.1	390	239	151	158	150	73	55	198	238

AP 03 • APS 03

Accessori
Accessories
Accessoires
Zubehören
Accesorios



SUPPORTO CILINDRO CYLINDER SUPPORT
PALIER VERIN LAGER ZYLINDER
SOPORTE CILINDRO



SUPPORTO BILANCIERE CRADLE SUPPORT
BALANCIER VERIN LAGER KIPPHEBEL
SOPORTE CUNA



BILANCIERE CRADLE BALANCIER
KIPPHEBEL CUNA



Vedi pagine 26 e 27 per dettagli
See pages 26-27 for details
Voyez pages 26-27 pour détails
Sehen Blatten 26-27 für Informationen
Ver hoias 26-27 para informaciones

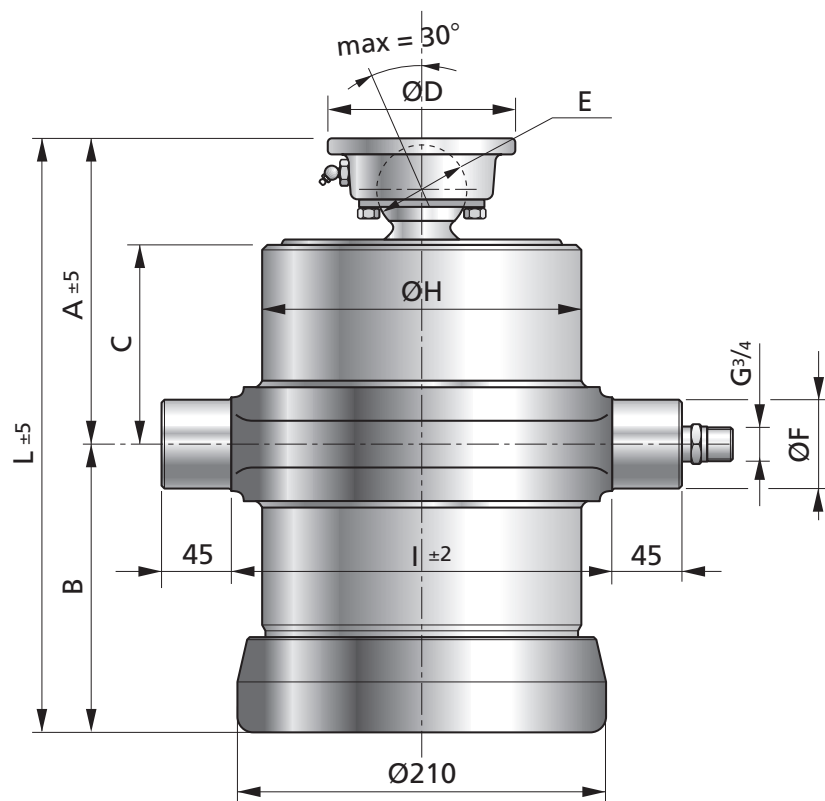

AP 03 • APS 03										
TIPO TYPE TYP TIPO	SFILATE EXTENSION EXPANSION STUFENZAHL EXPANSION	DIAMETRO - DIAMETER DIAMÈTRE - DURCHMESSER - DIAMETRO [mm]								max SPINTA THRUST POUSSEE KRAFT EMPUJE [kN]
		I	II	III	IV	V	VI	VII	VIII	
AP 03	6	154	135	116	98	79	61			164
	5	154	135	116	98	79				202
APS03	8	154	135	120	105	90	75	60	45	131
	7	154	135	120	105	90	75	60		160
	6	154	135	120	105	90	75			175
	5	154	135	120	105	90				221

AP 03 • APS 03 DETTAGLI TECNICI TECHNICAL DATA DÉTAIL TECHNIQUES TECHNISCHE DATUM DETALLES TÉCNICOS

ART. NUOVO NEW MODEL NOUVELLE DESCR. NEUE BEZEICHNUNG DESCRIPCION NUEVA	ART. VECCHIO OLD MODEL ANCIENNE DES. ALTE BEZ. DES. ANTIGUA	CODICE CODE CODE BESTELL.-Nr. CODIGO	N. SFILATE - EXTENSION N. N. DES BALLONGES STUFENZAHL - N. EXPANSIONES [mm]	CORSO - POWER STROKE COURSE DE TRAVAIL GESAMTHUB - CARRERA [mm]	MASSA - MASS MASSE - MASSE [kg]	OLIO ASSORBITO OIL CONSUMPTION HUILE CONSOMM. ÖLVERBRAUCH ACEITE ABSORBIDO [dm ³]	PRESSIONE MAX DI LAVORO MAX. WORKING PRESSURE PRESSION DE TRAVAIL MAX. MAXIMUM BETRIEBSDRUCK PRESSION MAX. DE TRABAJO [bar]	MASSA TOTALE RIBALTABILE TOTAL MASS TIP-UP MASSE TOTALE REBATABLE GESAMTTRIPPMASSE MASA TOTAL VOLCADA [ton]	L	A	B	C	D	E	F	H	I
AP75038361546	AP03/753/6	2107501546001	6	3836	132	37.6	300	25.1	880	223	657	118	120	58	55	177	216
AP75031961545	AP03/753/5	2107501545001	5	3196	122	35.8	300	30.8	882	225	657	118	150	73	55	177	216
AP67033561546	AP03/673/6	2106701546001	6	3356	120	32.9	300	25.1	800	223	577	118	120	58	55	177	216
AP67027961545	AP03/673/5	2106701545001	5	2796	110	31.3	300	30.8	802	225	577	118	150	73	55	177	216
APS56532531547	APS03/568/7	2205651547001	7	3253	105	30.8	300	24.4	702	230	472	118	120	58	55	177	216
APS56527861546	APS03/568/6	2205651546001	6	2786	96	29.5	300	29.1	695	223	472	118	120	58	55	177	216
APS56523181545	APS03/568/5	2205651545001	5	2318	92	27.4	300	33.9	697	225	472	118	150	73	55	177	216
APSL27631547	APSL03/7	22000L1547001	7	2763	104	26.1	300	24.4	632	230	402	118	120	58	55	177	216
APSL23661546	APSL03/6	22000L1546001	6	2366	86	25.0	300	29.1	625	223	402	118	120	58	55	177	216
APSL19681545	APSL03/5	22000L1545001	5	1968	83	23.3	300	33.9	627	225	402	118	150	73	55	177	216
AP547025881547	APS03/473/7	2204701547001	7	2588	90	24.5	300	24.4	607	230	377	118	120	58	55	177	216
AP547022161546	APS03/473/6	2204701546001	6	2216	84	23.4	300	29.1	600	223	377	118	120	58	55	177	216
AP547018431545	APS03/473/5	2204701545001	5	1843	80	21.8	300	33.9	602	225	377	118	150	73	55	177	216
APSH21171547	APSH03/7	22000H1547001	7	2117	83	20.5	300	24.4	519	230	289	158	120	58	55	177	216
APSH18331546	APSH03/6	22000H1546001	6	1833	79	19.7	300	29.1	519	230	289	158	120	58	55	177	216
APSH15411545	APSH03/5	22000H1545001	5	1541	76	18.4	300	33.9	528	239	289	158	150	73	55	177	216
APSM22191548	APSM03/8	2200AM1548001	8	2219	80	19.4	300	20.0	497	230	267	158	120	58	55	177	216
APSM19631547	APSM03/7	2200AM1547001	7	1963	79	19.0	300	24.4	497	230	267	158	120	58	55	177	216
APSM17011546	APSM03/6	2200AM1546001	6	1701	75	18.3	300	29.1	497	230	267	158	120	58	55	177	216
APSM14311545	APSM03/5	2200AM1545001	5	1431	71	17.1	300	33.9	506	239	267	158	150	73	55	177	216
APSB/A20751548	APSB03/8A	2200BA1548001	8	2075	77	18.2	300	20.0	479	230	249	158	120	58	55	177	216
APSB/A18371547	APSB03/7A	2200BA1547001	7	1837	75	17.8	300	24.4	479	230	249	158	120	58	55	177	216
APSB/A15931546	APSB03/6A	2200BA1546001	6	1593	71	17.1	300	29.1	479	230	249	158	120	58	55	177	216
APSB/A13411545	APSB03/5A	2200BA1545001	5	1341	68	16.0	300	33.9	488	239	249	158	150	73	55	177	216
APSB19391548	APSB03/8	22000B1548001	8	1939	72	16.9	300	20.0	454	242	212	158	120	58	55	177	216
APSB17101547	APSB03/7	22000B1547001	7	1710	70	16.5	300	24.4	452	240	212	158	120	58	55	177	216
APSB14781546	APSB03/6	22000B1546001	6	1478	66	15.8	300	29.1	450	238	212	158	120	58	55	177	216
APSB12411545	APSB03/5	22000B1545001	5	1241	64	14.8	300	33.9	457	245	212	158	150	73	55	177	216
APSC16331548	APSC03/8	22000C1548001	8	1633	67	14.4	300	20.0	409	230	179	158	120	58	55	177	216
APSC14491547	APSC03/7	22000C1547001	7	1449	65	14.2	300	24.4	409	230	179	158	120	58	55	177	216
APSC12601546	APSC03/6	22000C1546001	6	1260	62	13.6	300	29.1	409	230	179	158	120	58	55	177	216
APSC10641545	APSC03/5	22000C1545001	5	1064	60	12.8	300	33.9	418	239	179	158	150	73	55	177	216
APSCC14471548	APSCC03/8	2200CC1548001	8	1447	62	12.7	300	20.0	376	230	146	158	120	58	55	177	216
APSCC12831547	APSCC03/7	2200CC1547001	7	1283	61	12.4	300	24.4	376	230	146	158	120	58	55	177	216
APSCC11141546	APSCC03/6	2200CC1546001	6	1114	58	11.9	300	29.1	376	230	146	158	120	58	55	177	216
APSCC9381545	APSCC03/5	2200CC1545001	5	938	56	11.1	300	33.9	385	239	146	158	150	73	55	177	216

AP 04 • APS 04

1/2

Accessori
Accessories
Accessoires
Zubehören
Accesorios



SUPPORTO CILINDRO CYLINDER SUPPORT
PALIER VERIN LAGER ZYLINDER
SOPORTE CILINDRO



SUPPORTO BILANCIERE CRADLE SUPPORT
BALANCIER VERIN LAGER KIPPHEBEL
SOPORTE CUNA



BILANCIERE CRADLE BALANCIER
KIPPHEBEL CUNA



Vedi pagine 26 e 27 per dettagli
See pages 26-27 for details
Voyez pages 26-27 pour détails
Sehen Blatten 26-27 für Informationen
Ver hoías 26-27 para informaciones

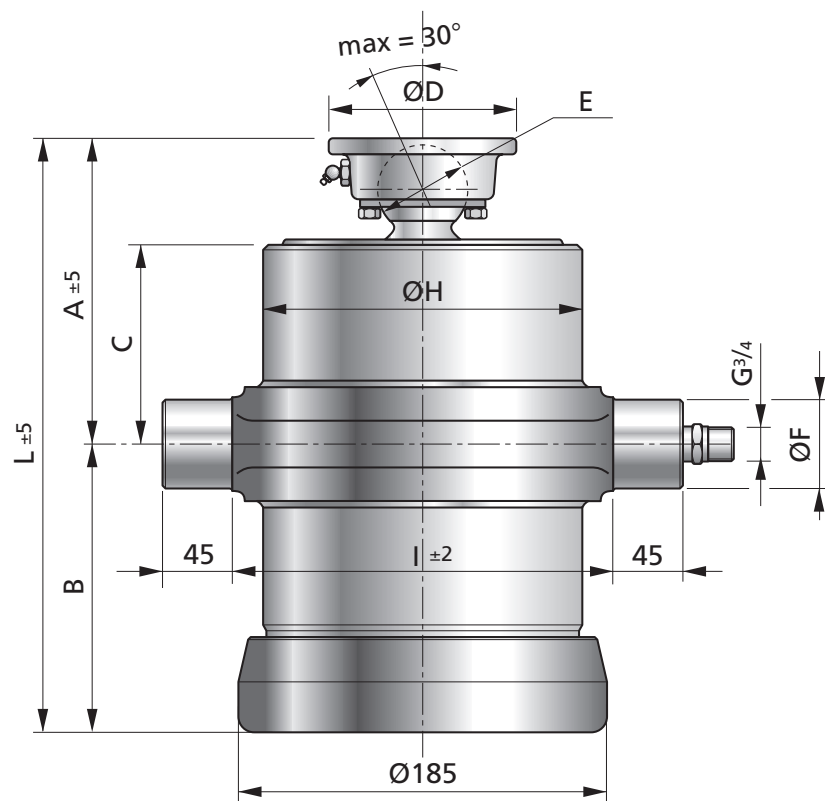

AP 04 • APS 04									
TIPO TYPE TYP TIPO	SFILATE EXTENSION EXPANSION STUFENZAHL EXPANSION	DIAMETRO - DIAMETER DIAMÈTRE - DURCHMESSER - DIAMETRO [mm]							max SPRINT THRUST POUSSEE KRAFT EMPUJE [kN]
		I	II	III	IV	V	VI	VII	
AP 04	5	135	116	98	79	61			139
	4	135	116	98	79				173
APS04	7	135	120	105	90	75	60	45	112
	6	135	120	105	90	75	60		139
	5	135	120	105	90	75			166
	4	135	120	105	90				194

AP 04 • APS 04 DETTAGLI TECNICI TECHNICAL DATA DÉTAIL TECHNIQUES TECHNISCHE DATUM DETALLES TÉCNICOS

ART. NUOVO NEW MODEL NOUVELLE DESCR. NEUE BEZEICHNUNG DESCRIPCION NUEVA	ART. VECCHIO OLD MODEL ANCIENNE DES. ALTE BEZ. DES. ANTIGUA	CODICE CODE CODE BESTELL-Nr. CODIGO	N. SFILATE - EXTENSION N. N. DES RALLONGES STUFENZAHL - N. EXPANSIONES	CORSO - POWER STROKE COURSE DE TRAVAIL GESAMTHUB - CARRERA	MASSA - MASS MASSE - MASSE	OLIO ASSORBITO OIL CONSUMPTION HUILE CONSUMM. ÖLVERBRAUCH ACEITE ABSORBIDO	PRESSIONE MAX DI LAVORO MAX. WORKING PRESSURE PRESSION DE TRAVAIL MAX. MAXIMUM BETRIEBSDRUCK PRESSION MAX. DE TRABAJO	MASSA TOTALE RIBALZABILE TOTAL MASS TIP-UP MASSE TOTALE REBATABLE GESAMTKIPPMASSSE MASA TOTAL VOLCADA	L	A	B	C	D	E	F	H	I
AP 750 3198 135 5	AP04/753/5	2107501355001	5	3198	108	25.7	300	21.3	871	216	655	118	120	58	55	157	192
AP 750 2558 135 4	AP04/753/4	2107501354001	4	2558	95	23.9	300	26.5	873	218	655	118	150	73	55	157	192
AP 670 2798 135 5	AP04/673/5	2106701355001	5	2798	97	22.5	300	21.3	791	216	575	118	120	58	55	157	192
AP 670 2238 135 4	AP04/673/4	2106701354001	4	2238	87	20.9	300	26.5	793	218	575	118	150	73	55	157	192
APS565 2795 135 6	APS04/568/6	2205651356001	6	2795	83	22.3	300	21.2	693	223	470	118	120	58	55	157	192
APS565 2328 135 5	APS04/568/5	2205651355001	5	2328	74	20.9	300	25.4	686	216	470	118	120	58	55	157	192
APS565 1860 135 4	APS04/568/4	2205651354001	4	1860	71	18.9	300	29.7	688	218	470	118	150	73	55	157	192
APSL 2375 135 6	APSL04/6	22000L1356001	6	2375	75	18.9	300	21.2	623	223	400	118	120	58	55	157	192
APSL 1978 135 5	APSL04/5	22000L1355001	5	1978	68	17.8	300	25.4	616	216	400	118	120	58	55	157	192
APSL 1580 135 4	APSL04/4	22000L1354001	4	1580	65	16.0	300	29.7	618	218	400	118	150	73	55	157	192
AP S470 2225 135 6	APS04/473/6	2204701356001	6	2225	72	17.7	300	21.2	598	223	375	118	120	58	55	157	192
AP S470 1853 135 5	APS04/473/5	2204701355001	5	1853	65	16.7	300	25.4	591	216	375	118	120	58	55	157	192
AP S470 1480 135 4	APS04/473/4	2204701354001	4	1480	63	15.0	300	29.7	593	218	375	118	150	73	55	157	192
AP SH 1800 135 6	APSH04/6	22000H1356001	6	1800	66	14.6	300	21.2	510	230	280	158	120	58	55	157	192
AP SH 1516 135 5	APSH04/5	22000H1355001	5	1516	60	13.8	300	25.4	510	230	280	158	120	58	55	157	192
AP SH 1224 135 4	APSH04/4	22000H1354001	4	1224	58	12.5	300	29.7	519	239	280	158	150	73	55	157	192
AP SM 1924 135 7	APSM04/7	2200AM1357001	7	1924	63	13.9	300	17.2	488	230	258	158	120	58	55	157	192
AP SM 1668 135 6	APSM04/6	2200AM1356001	6	1668	60	13.5	300	21.2	488	230	258	158	120	58	55	157	192
AP SM 1406 135 5	APSM04/5	2200AM1355001	5	1406	56	12.8	300	25.4	488	230	258	158	120	58	55	157	192
AP SM 1136 135 4	APSM04/4	2200AM1354001	4	1136	55	11.6	300	29.7	497	239	258	158	150	73	55	157	192
AP SB/A 1798 135 7	APSB04/7A	2200BA1357001	7	1798	62	13.1	300	17.2	470	230	240	158	120	58	55	157	192
AP SB/A 1560 135 6	APSB04/6A	2200BA1356001	6	1560	60	12.7	300	21.2	470	230	240	158	120	58	55	157	192
AP SB/A 1316 135 5	APSB04/5A	2200BA1355001	5	1316	55	12.0	300	25.4	470	230	240	158	120	58	55	157	192
AP SB/A 1064 135 4	APSB04/4A	2200BA1354001	4	1064	54	10.9	300	29.7	479	239	240	158	150	73	55	157	192
AP SC 1410 135 7	APSB04/7	22000C1357001	7	1685	58	12.1	300	17.2	445	240	205	158	120	58	55	157	192
AP SB 1456 135 6	APSB04/6	22000B1356001	6	1456	56	11.8	300	21.2	443	238	205	158	120	58	55	157	192
AP SB 1224 135 5	APSB04/5	22000B1355001	5	1224	52	11.1	300	25.4	441	236	205	158	120	58	55	157	192
AP SB 987 135 4	APSB04/4	22000B1354001	4	987	51	10.1	300	29.7	448	243	205	158	150	73	55	157	192
AP SC 1410 135 7	APSC04/7	22000C1357001	7	1410	53	10.3	300	17.2	400	230	170	158	120	58	55	157	192
AP SC 1226 135 6	APSC04/6	22000C1356001	6	1226	51	10.0	300	21.2	400	230	170	158	120	58	55	157	192

AP 04 • APS 04

2/2

Accessori
Accessories
Accessoires
Zubehören
Accesorios



SUPPORTO CILINDRO CYLINDER SUPPORT
PALIER VERIN LAGER ZYLINDER
SOPORTE CILINDRO



SUPPORTO BILANCIERE CRADLE SUPPORT
BALANCIER VERIN LAGER KIPPEBEL
SOPORTE CUNA



BILANCIERE CRADLE BALANCIER
KIPPEBEL CUNA



Vedi pagine 26 e 27 per dettagli
See pages 26-27 for details
Voyez pages 26-27 pour détails
Sehen Blatten 26-27 für Informationen
Ver hoias 26-27 para informaciones

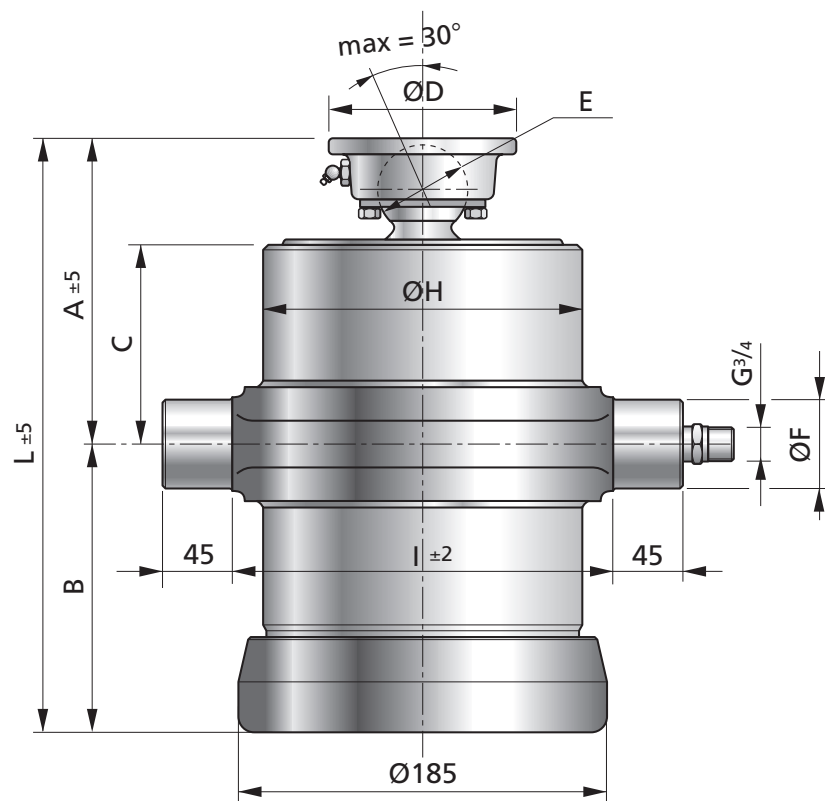

AP 04 • APS 04									
TIPO TYPE TYP TIPO	SFILATE EXTENSION EXPANSION STUFENZAHL EXPANSION	DIAMETRO - DIAMETER DIAMÈTRE - DURCHMESSER - DIAMETRO [mm]							max SPRINT THRUST POUSSEE KRAFT EMPUJE [kN]
		I	II	III	IV	V	VI	VII	
AP 04	5	135	116	98	79	61			139
	4	135	116	98	79				173
APS04	7	135	120	105	90	75	60	45	112
	6	135	120	105	90	75	60		139
	5	135	120	105	90	75			166
	4	135	120	105	90				194

AP 04 • APS 04 DETTAGLI TECNICI TECHNICAL DATA DÉTAIL TECHNIQUES TECHNISCHE DATUM DETALLES TÉCNICOS

ART. NUOVO NEW MODEL NOUVELLE DESCR. NEUE BEZEICHNUNG DESCRIPCION NUEVA	ART. VECCHIO OLD MODEL ANCIENNE DES. ALTE BEZ. DES. ANTIGUA	CODICE CODE CODE BESTELL-Nr. CODIGO	N. SFILATE - EXTENSION N. N. DES RALLONGES N. EXPAISIONES STUFENZAHL - N. EXPAISIONES	CORSA - POWER STROKE COURSE DE TRAVAIL GESAMTHUB - CARRERA	MASSA - MASS MASSE - MASSE MASA	OLIO ASSORBITO OIL CONSUMPTION HUILE CONSOMM. ÖLVERBRAUCH ACEITE ABSORBIDO	PRESSIONE MAX DI LAVORO MAX. WORKING PRESSURE PRESSION DE TRAVAIL MAX. MAXIMUM BETRIEBSDRUCK PRESSION MAX. DE TRABAJO	MASSA TOTALE RIBALZABILE TOTAL MASS TIP-UP MASSE TOTALE REBATABLE GESAMTKIPPMASSSE MASA TOTAL VOLCADA	L	A	B	C	D	E	F	H	I
APSC 1037 135 5	APSC04/5	22000C1355001	5	1037	48	9.5	300	25.4	400	230	170	158	120	58	55	157	192
APSC 841 135 4	APSC04/4	22000C1354001	4	841	47	8.6	300	29.7	409	239	170	158	150	73	55	157	192
APSCC 1257 135 7	APSCC04/7	2200CC1357001	7	1257	49	9.1	300	17.2	367	230	137	158	120	58	55	157	192
APSCC 1093 135 6	APSCC04/6	2200CC1356001	6	1093	48	8.9	300	21.2	367	230	137	158	120	58	55	157	192
APSCC 924 135 5	APSCC04/5	2200CC1355001	5	924	45	8.4	300	25.4	367	230	137	158	120	58	55	157	192
APSCC 748 135 4	APSCC04/4	2200CC1354001	4	748	44	7.6	300	29.7	376	239	137	158	150	73	55	157	192

Accessori • Accessories • Accessoires Zubehören • Accesorios

SUPPORTO CILINDRO CYLINDER SUPPORT PALIER VERIN LAGER ZYLINDER SOPORTE CILINDRO

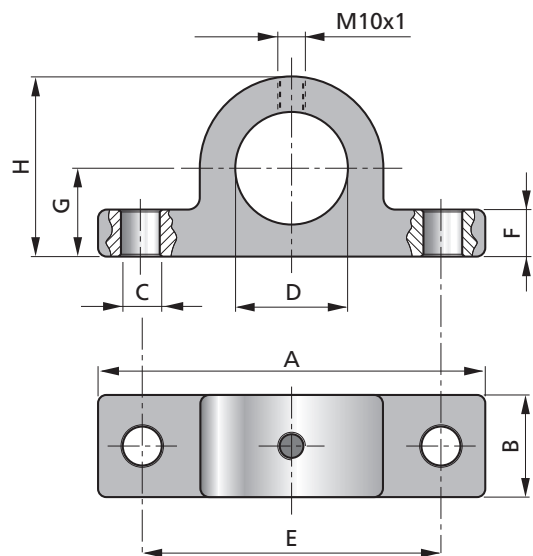

SC 45 - SC 50 - SC 55 - SC 70

ART. NUOVO NEW MODEL NOUVELLE D. NEUE BEZ. DES. NUEVA	ART. VECCHIO OLD MODEL ANCIENNE D. ALTE BEZ. DES. ANTIGUA	CODICE CODE BESTELL-Nr. CODIGO	A	B	C	D	E	F	G	H	MASSA MASS MASSE MASSE MASA [kg]
SC45	SC45	A70045001	140	40	14	45.5	108	17	32	65	1.5
SC50	SC50	A70050001	150	45	15	50.5	113	15	45	80	2.6
SC55	SC55	A70055001	150	45	15	55.5	113	15	45	80	2.6
SC70	SC70	A70070001	180	45	16.5	70.5	140	15	47.5	95	3

SUPPORTO BILANCIERE CRADLE SUPPORT BALANCIER VERIN LAGER KIPPHEBEL SOPORTE CUNA

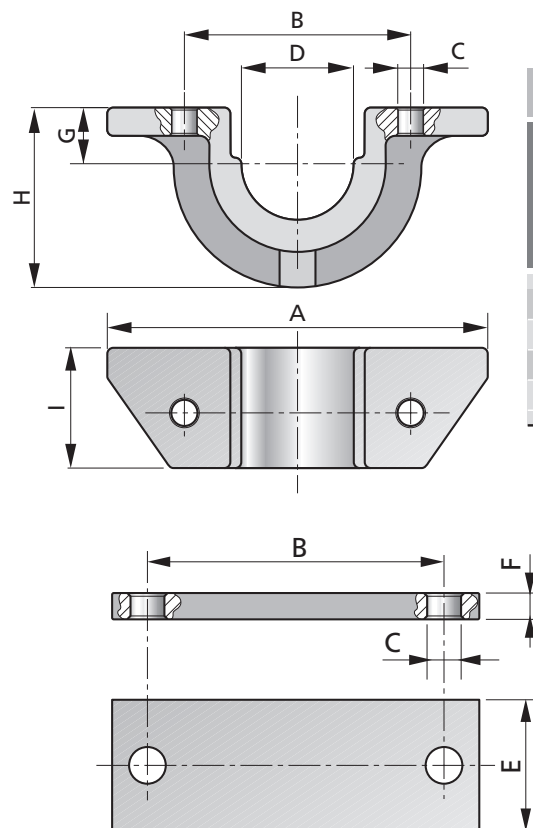

SB 45 - SB 50 - SB 55 - SB 70

ART. NUOVO NEW MODEL NOUVELLE D. NEUE BEZ. DES. NUEVA	ART. VECCHIO OLD MODEL ANCIENNE D. ALTE BEZ. DES. ANTIGUA	CODICE CODE BESTELL-Nr. CODIGO	A	B	C	D	E	F	G	H	I	MASSA MASS MASSE MASSE MASA [kg]
SB45	SB45	A60045001	145	113	13	45.5	30	8	23	56	40	1
SB50	SB50	A60050001	190	113	13	51	30	8	25.5	70	45	2
SB55	SB55	A60055001	190	113	13	56	30	8	28	70	45	2
SB70	SB70	A60070001	210	148	13	71	30	8	35.5	150	45	3

BILANCIERE CRADLE BALANCIER KIPPHEBEL CUNA

AP1 - AP01 - AP02 - AP03 - AP04

ART. NUOVO NEW MODEL NOUVELLE D. NEUE BEZ. DES. NUEVA	ART. VECCHIO OLD MODEL ANCIENNE D. ALTE BEZ. DES. ANTIGUA	CODICE CODE BESTELL-Nr. CODIGO	PORTATA MAX MAX CAPACITY PORTÉE MAX MAX TRAGKRAFT CAPACIDAD MAX [ton]	A	B	C	D	E	F	G	H	I	J	K	L	MASSA MASS MASSE MASSE MASA [kg]
AP1	AP1	A51000003	43	502	452	72	70	393	75	145	171	303	15	25	592	45
AP01	AP01	A50100003	38	448	407	57	55	338	65	130	151	258	15	17.5	538	31
AP02	AP02	A50200003	33	448	407	57	55	321	65	130	151	241	15	17.5	538	31
AP03	AP03	A50300003	23	326	291	57	55	289	50	95	123	219	12	10.5	416	18
AP04	AP04	A50400003	21	326	291	57	55	265	50	95	123	195	12	10.5	416	18

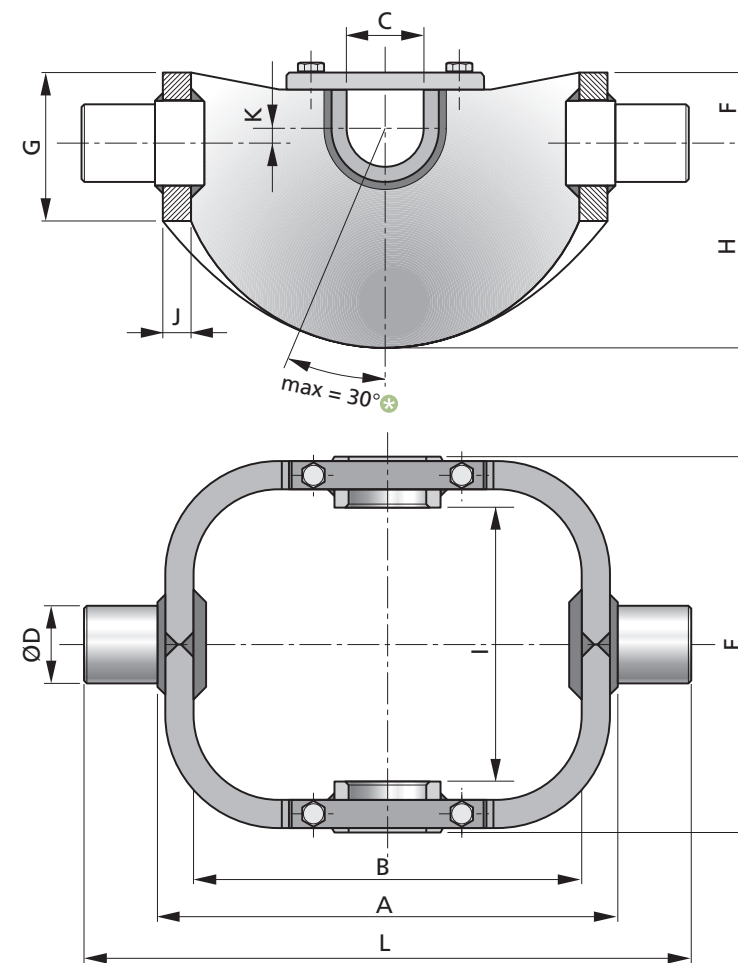

* For APSC 03: max 27°
For APSCC 03: max 25°

Tavole di Aiuto • Selection charts Tables de choix • Vorwählerkarte Carta de seleccion

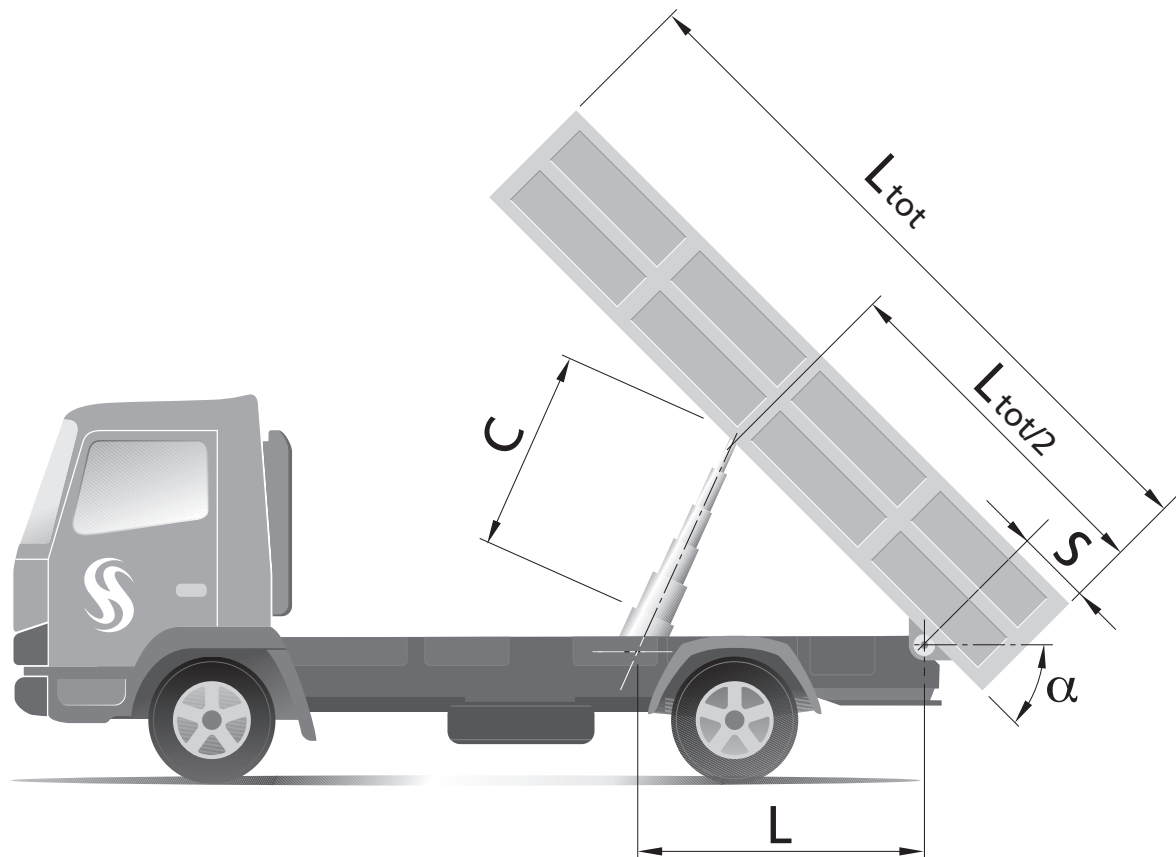

Corsa • Stroke • Course • Hub • Carrera

L [mm]	INCLINAZIONE CASSONE - BODY TILTING ANGLE DE BENNAGE - KIPPWINKEL - ANGULO DE VUELCO α [°]					
	40	45	48	50	55	60
600	410	459	488	507	554	600
800	547	612	651	676	739	800
1000	684	765	813	845	923	1000
1200	821	918	976	1014	1108	1200
1400	958	1072	1139	1183	1293	1400
1600	1094	1225	1302	1352	1478	1600
1800	1231	1378	1464	1521	1662	1800
2000	1368	1531	1627	1690	1847	2000
2200	1505	1684	1790	1860	2032	2200
2400	1642	1837	1952	2029	2216	2400
2600	1779	1990	2115	2198	2401	2600
2800	1915	2143	2278	2367	2586	2800
3000	2052	2296	2440	2536	2770	3000
3200	2189	2449	2603	2705	2955	3200
3500	2394	2679	2847	2958	3232	3500
4000	2736	3061	3254	3381	3694	4000
4500	3078	3444	3661	3804	4156	4500
5000	3420	3827	4067	4226	4617	5000
5500	3762	4210	4474	4649	5079	5500
6000	4104	4592	4881	5071	5541	6000

CORSA
POWER STROKE
COURSE DE TRAVAIL
GESAMTHUB
CARRERA
C
[mm]

$$C_{[mm]} = 2L_{[mm]} \sin\left(\frac{\alpha_{[rad]}}{2}\right) \Rightarrow$$

$$\Rightarrow C_{[mm]} \cong \frac{3,1416}{180} \cdot \alpha_{[°]} \cdot L_{[mm]} \cdot \left(1 - \frac{9,8696}{777600} \alpha_{[°]}^2\right)$$

- Conoscendo la distanza del cilindro dalle cerniere del cassone e l'angolo che si vorrebbe ottenere, si ricava un valore indicativo della corsa che il cilindro deve erogare.
- The stroke is identified by crossing the pivot length (L) with the requested tipping angle (°).
- La course est calculée sur la distance des charnières et l'angle de bennage.
- Sie koennen die Zylinderhub von Kippwellenabstand und Kippwinkelangabe ziehen.
- La carrera es de distancia del cilindro desde el punto de giro e l'angulo de volcada

Spinta • Thrust • Poussée • Kraft • Empuje

SFIILATE EXTENSION EXPANSION STUFENZAHL EXPANSION Ø [mm]	PRESSIONE - PRESSURE PRESSION - DRUCK - PRESIÓN [bar]									
	50	100	125	150	175	200	225	250	275	300
45	8	16	20	24	28	32	36	40	44	48
60	14	28	35	42	49	57	64	71	78	85
61	15	29	37	44	51	58	66	73	80	88
75	22	44	55	66	77	88	99	110	121	133
79	25	49	61	74	86	98	110	123	135	147
90	32	64	80	95	111	127	143	159	175	191
98	38	75	94	113	132	151	170	189	207	226
105	43	87	108	130	152	173	195	216	238	260
116	53	106	132	159	185	211	238	264	291	317
120	57	113	141	170	198	226	254	283	311	339
135	72	143	179	215	250	286	322	358	394	429
154	93	186	233	279	326	373	419	466	512	559
174	119	238	297	357	416	476	535	594	654	713
196	151	302	377	453	528	603	679	754	830	905
221.5	193	385	482	578	674	771	867	963	1060	1156
249	243	487	609	730	852	974	1096	1217	1339	1461
279	306	611	764	917	1070	1223	1376	1528	1681	1834

SPINTA
THRUST
POUSSEE
KRAFT
EMPUJE
[kN]

$$S_{[kN]} = \frac{\pi}{4} d_{[mm]}^2 \frac{p_{[bar]}}{10000} \Rightarrow$$

$$\Rightarrow S_{[kN]} \cong \frac{0,785}{10000} d_{[mm]}^2 p_{[bar]}$$

- La spinta è la forza che la pressione dell'olio genera agendo sullo stelo di un cilindro. Il diametro è il diametro di tenuta dello stelo.
- The thrust is a force generated by oil under pressure, which lifts the stage of the cylinder. "D" is the diameter of the stage.
- La poussée est la force de la huile en pression sous le expansion du vérin. D est le diamètre de chaque expansion.
- S ist die Kraft von Druck den Öl auf die Stufe. "D" ist die Durchmesser jeder Stufen.
- El empuje es la fuerza de l'aceite en presion en las expansiones. D es el diametro de cada expansion.

Quick reference selection chart

TIPO TYPE TYPE TYP TIPO	MASSA TOTALE - TOTAL MASS - MASSE TOTALE - GESAMTKIPPMASSE - MASA TOTAL [ton]											
	70+65	65+54	54+48	48+45	45+40	40+35	35+32	32+29	29+25	25+22	22+19	19+15
AP3	7	8		9	10							
AP2	6	7	8	9	10							
AP1		6	7	8		9	10					
AP01			5	6	7		8	9		10		
AP02					5	6	7		8	9		
AP03							5	6		7	8	
AP04								4	5		6	7

N. SFIILATE
EXTENSION N.
DES BALLONGES
STUFENZAHL
N. EXPANSIONES

- Conoscendo la massa totale ribaltabile si possono individuare i modelli di cilindri che normalmente possono essere utilizzati con il carico previsto.
- Depending on the total tipping weight, the chart identifies the most suitable model and number of stages available.
- En choisissant le poids total de bennage, le tableau identifie le modele optimale de vérin et le nombre de expansions disponibles.
- Bei der Tabelle mit der Gesamtkippmasse können Sie den optimal Zylinder wahlen.
- Con este tabllilla conociendo la masa total de vuelco se puede seleccionar el cilindro optimal.

Complessivo · Assembly · Plan du vérin Zusammenzeichnung · Dibujo

Avvertenze · Warnings · Advertissement Warnungen · Advertencias

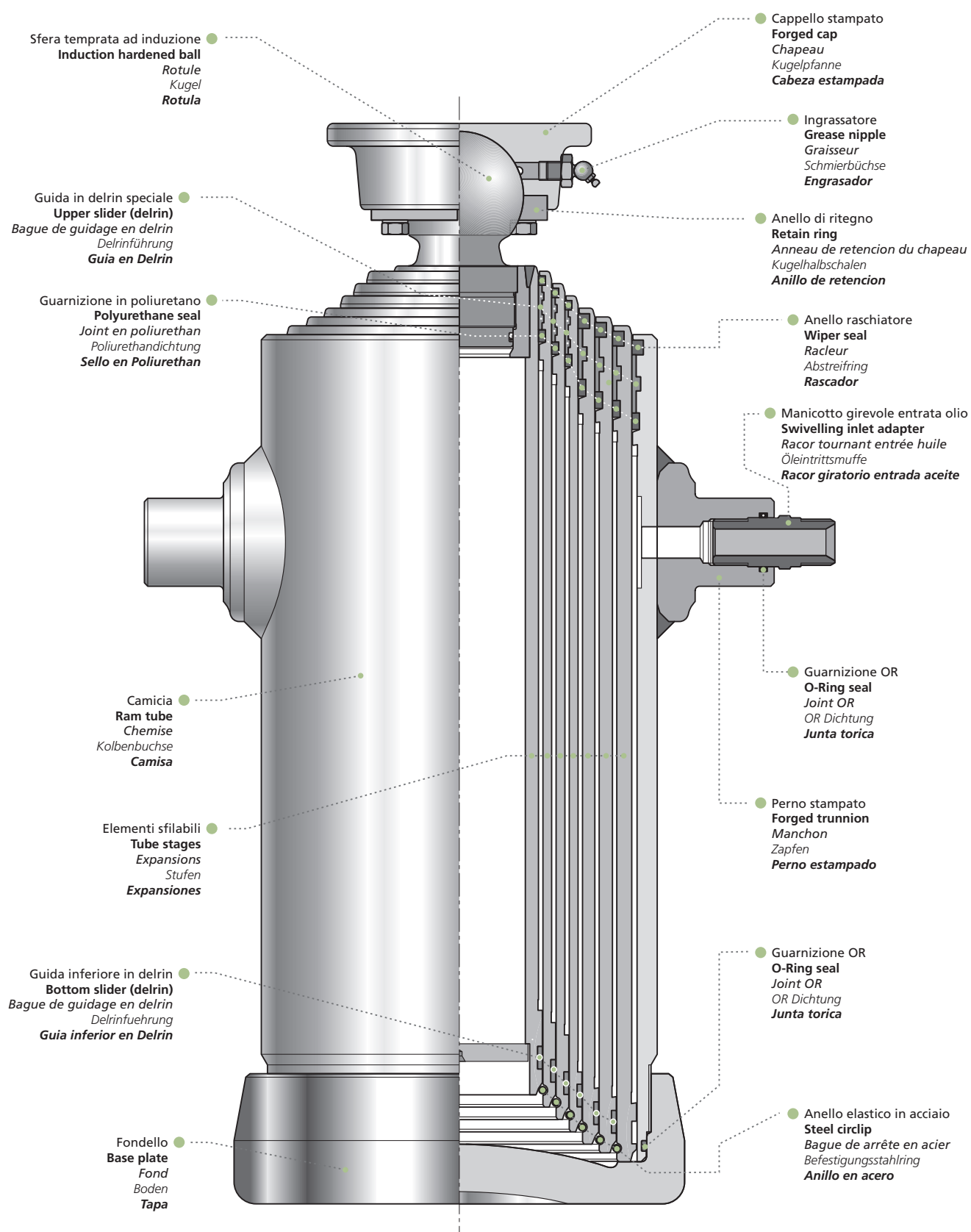

I Il presente catalogo sottopone alla Spettabile Clientela la gamma completa dei cilindri idraulici telescopici per ribaltabili di produzione della H.S. PENTA. Tutti i cilindri sono componenti che possono essere incorporati in macchine che devono rispettare i requisiti essenziali di sicurezza della Direttiva Macchine 98/37CE e successive modifiche. Si presuppone che la macchina in cui sarà incorporato sia conforme a tali direttive e che rispetti le condizioni d'uso.

Condizioni d'uso. L'esercizio ordinario del cilindro telescopico prevede che esso venga utilizzato per sollevare cassoni di veicoli per il ribaltamento progressivo su tutta la lunghezza della corsa del materiale ivi contenuto nel rispetto delle condizioni di uso. La massa del cassone più la massa del materiale contenuto danno la massa totale ribaltabile, i cui valori riportati sono indicativi delle prestazioni che si possono ottenere nello scaricamento in condizioni normali. Il cilindro è stato dimensionato per sostenere sforzi diretti lungo il suo asse, non deve perciò essere assoggettato a carichi diversi da quelli previsti (per esempio carichi laterali).

GB This catalogue lists the whole range of H.S. PENTA under-body hoists for tippers, standard type. Cylinders should be integrated into machines manufactured according to the safety requirements and technical provisions specified by the European Community, Machinery Directive nr. 98/37 CE, and subsequent modifications. The machinery must comply with the previously mentioned Directive and relevant operating conditions.

Fitment suggestions and operating conditions. The normal application of multi-stage cylinder is to lift up tipping bodies, loaded with different materials, and consequently discharge this material whilst the cylinder is extended all along its stroke. The body weight plus the payload are the total lifting weight that must be raised by the cylinder. This value, calculated at the working pressure, is a rough indication of the tipping power of the cylinder. The cylinders have been sized for loads along the longitudinal axis (e.g. no side load is admitted).

F Par ce catalogue nous avons le plaisir de présenter à nos Clients toute la gamme des vérins télescopique de benne fabriqués par H.S. PENTA. Tous les vérins sont un sous-groupe qui peuvent être incorporés dans machine que doivent respecter les réquisitionnés essentiels de sécurité de la Directive Communautaire 98/37 CE et modifications suivantes. On imagine que la machine dans la quelle il sera incorporé est-il conforme à cette Directives et que-t-il respect les conditions d'utilisation.

Conditions diutilisation. L'exercice ordinaire du vérin télescopique prévoit que-t-il sera utilisé pour lever benne basculantes du camion pour le renversement progressif sur toute la longueur de la course du material là contenu dans le respect des conditions d'utilisation. La masse de la benne plus la masse du matériel contenu donne la masse totale basculante, dont les valeurs mentionnés sont calculés à la pression du travail et sont indicatives des performance que on peuvent obtenir dans les déchargement en conditions normal. Le vérin a été dimensionné pour soutenir efforts direct le long de son axe, c'est pourquoi que ne doit pas être assujeté à des charges different de ce-là prévu (par exemple charges lateral).

D Verehrter Kunde, wir freuen uns, Ihnen mit diesem Katalog das gesamte H.S.PENTA-Fertigungsprogramm von hydraulischen Teleskopzylindern für Lastkraftwagen mit Kippvorrichtung vorstellen zu können. Alle Zylinder sind Bauteile, die in Maschinen, die den Mindestanforderungen der EG-maschinenrichtlinie 98/37 und deren späteren Änderungen genügen müssen, eingebaut werden können. Es wird vorausgesetzt, daß die Maschine, in die der Zylinder eingebaut wird, dieser Richtlinie entspricht und daß die Betriebsbedingungen eingehalten werden.

Betriebsbedingungen. Der normale Bestimmungszweck des Teleskopzylinder sieht vor, daß er zum Anheben von Fahrzeugpritschen verwendet wird, um so das Ladegut durch fortschreitendes Kippen über die ganze Hublänge unter Einhaltung der Betriebsbedingungen auszuschütten. Pritschenmasse und Ladegutmasse ergeben die Gesamtkippmasse. Bei den für sie angegebenen Werten, die zu Betriebsdruck berechnet sind, handelt es sich um Richtwerte, die beim Entladen unter normalen Bedingungen erreicht werden können. Der Zylinder wurde so ausgelegt, daß er Belastungen, die direkt längs seiner Achse wirken, aufnehmen kann.

E El presente catálogo muestra a nuestros apreciados clientes la gama completa de los cilindros hidráulicos para basculante producidos por H.S.PENTA. Todos los cilindros son componentes que se pueden incorporar en máquinas que deben respetar los requisitos esenciales de seguridad de la Directiva en máquinas 98/37CE y sucesivas modificaciones. Se presuppone que la máquina en la que será incorporado será conforme a tales directivas y respetará las condiciones de empleo.

Condiciones de empleo. La función habitual del cilindro telescópico prevé que sea utilizado para elevar cajas de vehículos con un basculamiento progresivo, sobre toda la largura de la carrera, de la carga incluida en el interior de la caja con respecto de las condiciones de empleo. El peso de la caja, más el peso del material contenido en ella da el peso total a bascular, cuyos valores estan calculados a la presión de trabajo y son indicativos de las prestaciones que se pueden obtener en la descarga en condiciones normales. El cilindro ha sido calculado para soportar esfuerzos directos a lo largo de su eje, por esto, no debe ser sometido a cargas diferentes a aquéllas previstas (por ejemplo carga lateral).

Sono elencati alcuni accorgimenti essenziali per un corretto montaggio del cilindro:

- 1) Nell'operazione di montaggio proteggere il cilindro dalle gocce di saldatura o da altri corpi estranei;
- 2) Nell'impianto applicare la valvola di massima pressione;
- 3) Curare bene l'impianto con l'applicazione di adeguati filtri, con la massima pulizia del serbatoio e delle tubazioni e l'uso di olii di qualità per impianti oleodinamici;
- 4) Montare sempre un dispositivo di fine corsa, lasciando al cilindro circa il 5% della corsa non utilizzato;
- 5) Il cassone in posizione di riposo non deve essere appoggiato sul cilindro.
- 6) Per evitare chiusure violente del cassone in caso di brusche interruzioni dell'alimentazione idraulica (per esempio per la rottura di un tubo o per il distacco di un raccordo) si può installare sui cilindri H.S. PENTA il dispositivo C.B.S. (Cylinder Blocking System) di produzione della H.S. PENTA stessa.

A few hints for correct fitment of the cylinder:

- 1) Protect the top of the cylinder from welding spatter, or other foreign particles;
- 2) Always fit a relief valve in the hydraulic pressure line. The relief valve must be set at a pressure lower than the max admitted for the cylinder (see specification for each cylinder);
- 3) Fit a filter in the hydraulic line, flush the oil tank and pipes, use good quality hydraulic oil;
- 4) Always fit an end-of-stroke device and leave a part of the stroke unused (recommended value 5% of the total stroke);
- 5) The tipper body should not rest on the cylinder. The cylinder should be extended at least 30 mm (when the tipper body is fully loaded).

Ci de suite nous vous donnons quelques précautions à adopter pour obtenir un montage correct du vérin:

- 1) Pendant le montage, protéger le vérin des gouttes de soudure ou de tout corps étranger;
- 2) L'installation doit être équipée d'un limiteur de pression. Le vérin doit travailler à une valeur inférieure par rapport à la pression du travail max. (Voir notre catalogue);
- 3) L'entretien de l'installation doit être bien soignée: utiliser des filtres convenables, rincer soigneusement le réservoir et le tubulures, employer des huiles de très bonnes qualité indiquées par les installations hydrauliques;
- 4) Permettant une course inutilisée du vérin d'environ le 5%;
- 5) Lorsque la caisse est en position de repos, elle ne doit pas appuyer sur le vérin. Le vérin doit rester ouvert au moins 30mm quand le camion est complètement chargé.

Er darf daher keinen anderen Belastungen als den vorgesehenen unterworfen werden (z.B. seitliche Belastungen).

- Beim Einbau der Zylinder sollte folgendes beachtet werden:
- 1) Während der Montage ist der Zylinder gegen Fremdkörper und beim schweißen entstehende Tropfen zu schützen;
 - 2) Es muß ein Überdruckventil in die Anlage eingebaut werden. Der Teleskopzylinder soll bei einem niedrigen Wert in bezug auf den maximum Betriebsdruck jedes Zylinders arbeiten (bitte schlagen Sie unsere Kataloge nach);
 - 3) Dafür sorgen, daß geeignete Filter eingebaut werden, daß Tank und Leitungen sauber sind und daß Qualitätsöl für Hydraulikanlagen verwendet wird;
 - 4) Stets eine Hubbegrenzungen einbauen, wobei eine von dem Zylinder nicht genutzte Hublänge von etwa 5% zu lassen ist;
 - 5) In Transportlage darf die Pritsche nie auf dem Zylinder aufliegen. Der Zylinder soll geöffnet mindestens 30mm bleiben, wenn der Fahrzeug völlig belastet ist.

A continuació, relacionamos algunos consejos esenciales para montar correctamente el cilindro:

- 1) En el montaje proteger el cilindro de las gotas de soldadura y de otros cuerpos extraños.
- 2) En la instalación poner válvula de seguridad de presión. El cilindro tiene que trabajar a un valor inferior respecto a la presión máxima de trabajo que está indicado en nuestro catalogo.
- 3) Poner mucha atención en la instalación de filtros, en una buena limpieza del depósito y de los latiguillos y usar aceite de calidad en la instalación hidráulica.
- 4) Montar siempre válvula final de carrera, dejando siempre un 5% de la carrera del cilindro sin utilizar.
- 5) La caja en posición de reposo no se debe apoyar sobre el cilindro. El cilindro tiene que quedarse abierto por lo menos 30mm cuando el camion está completamente cargado.



PENTA
Hydraulic Power

Hydro Service Penta
via Proventa, 31
48018 Faenza RA - Italy
tel. +39 0546 664848
fax +39 0546 664860
hspenta@hspenta.it
www.hspenta.it

.....
• Il presente catalogo annulla e sostituisce i precedenti.
La HS PENTA si riserva il diritto di apportare modifiche migliorative senza preavviso.
È vietata la riproduzione anche parziale.

• This catalogue cancels and replaces the previous ones.
HS PENTA reserves the right to make any improving changes without notice.
All right reserved.

• Ce catalogue annule et remplace le précédents.
HS PENTA se réserve le droit d'apporter des modifications améliorantes sans préavis.
La reproduction même partielle est interdite.

• Der vorliegende katalog annulliert und ersetzt die vorherigen.
HS PENTA behält sich das recht vor, besserungsänderungen ohne voranzeige anzubringen.
Reproduktionen, auch auszugsweise, sind verboten.

• Esto catalogo anula y reemplaza los anteriores.
HS PENTA se reserva el derecho de efectuar modificaciones de mejora sin previo aviso.
La reproduccion total o parcial esta prohibida.